

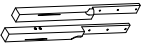









# ASSEMBLY INSTRUCTIONS INSTRUCCIONES

# B1400-Q-HB/ B1400-Q-FB/ B1400-KQ-RAIL QUEEN BED

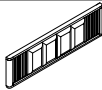
(BOX 1) BOX 1 OF HEADBOARD			
NO	DESCRIPTION	OUTLOOK	QTY
1	HEADBOARD		1
2	K/D LEG (L/R)		2
3	STRETCHER		1
(BOX 1) HARDWARE LIST			
NO	DESCRIPTION	OUTLOOK	QTY
A	BOLT	 Ø5/16" -18x2"L	10
B	ALLEN KEY	 5MM	1
C	SCREW	 #8x1-1/4"L	8
ASSEMBLY TOOL NOT INCLUDED			

(BOX 2) BOX 2 OF FOOTBOARD			
NO	DESCRIPTION	OUTLOOK	QTY
4	FOOTBOARD		1
5	BUN FOOT		2
6	SLATS		4
7	SUPPORT LEG		4
(BOX 3) BOX 3 OF SIDE RAIL			
NO	DESCRIPTION	OUTLOOK	QTY
8	SIDE RAIL (R/L)		2

THE HARDWARE IS LOCATED IN THE PACKING ITEMS.

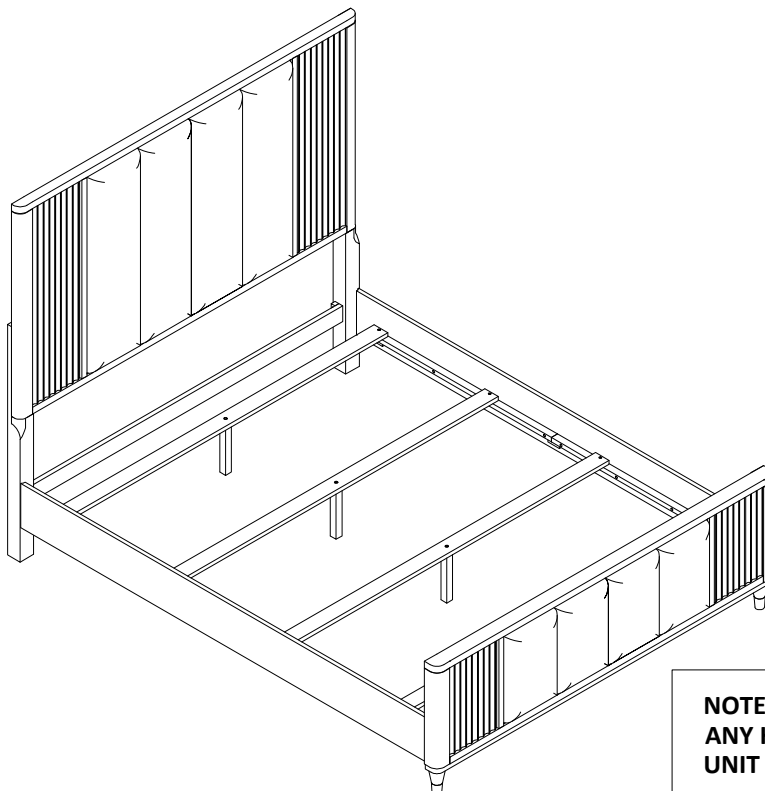

**NOTE : DURING ASSEMBLY, DO NOT FULLY TIGHTEN ANY HARDWARE UNTIL THE COMPLETE UNIT HAS BEEN ASSEMBLED.**

**NOTE: Periodically check to ensure that all connectors (bolts, screws, etc.) are tight.**

**NOTA: Verifique periódicamente que todos los conectores (tuercas, tornillos, etc.) esté bien apretados**

**ASSEMBLY INSTRUCTIONS**  
**INSTRUCCIONES**

**B1400-Q-HB/ B1400-Q-FB/ B1400-KQ-RAIL**  
**QUEEN BED**

**STEP 1**

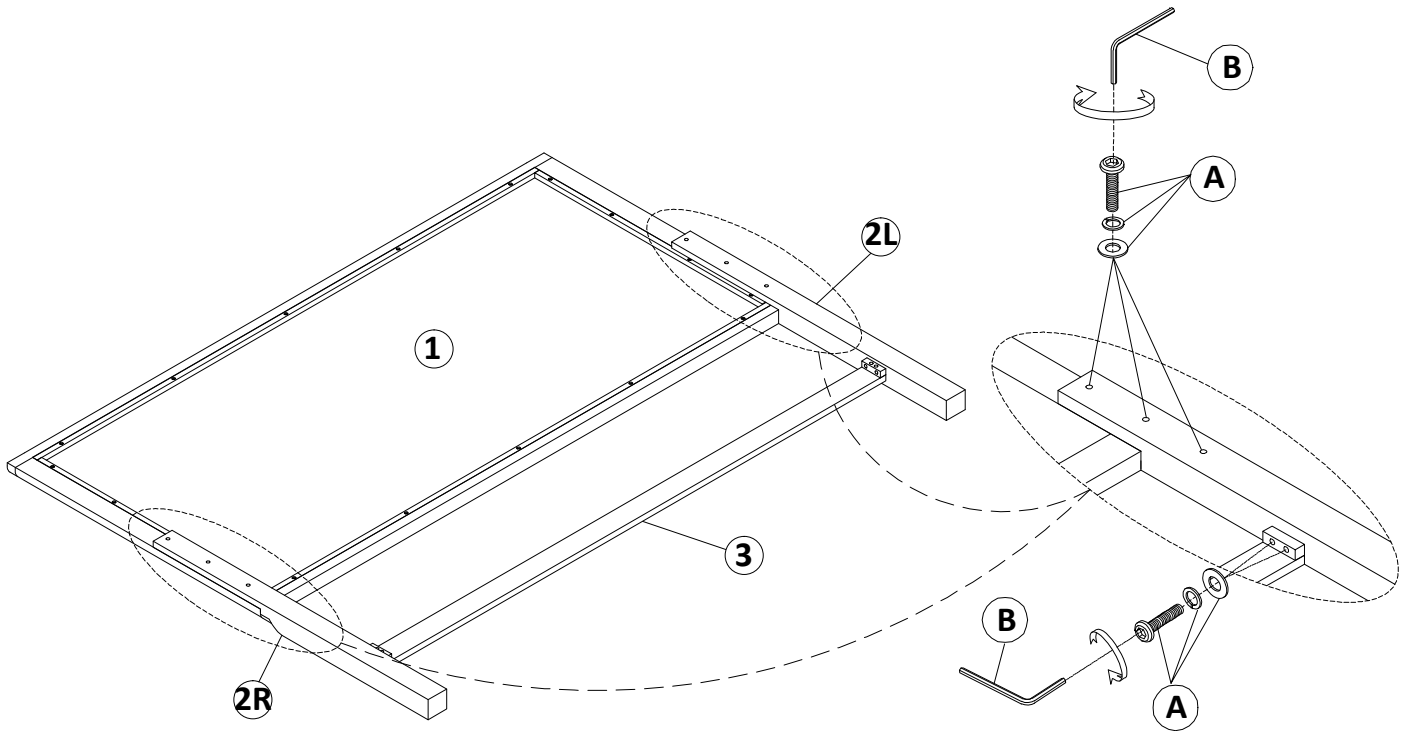

**STEP 2**

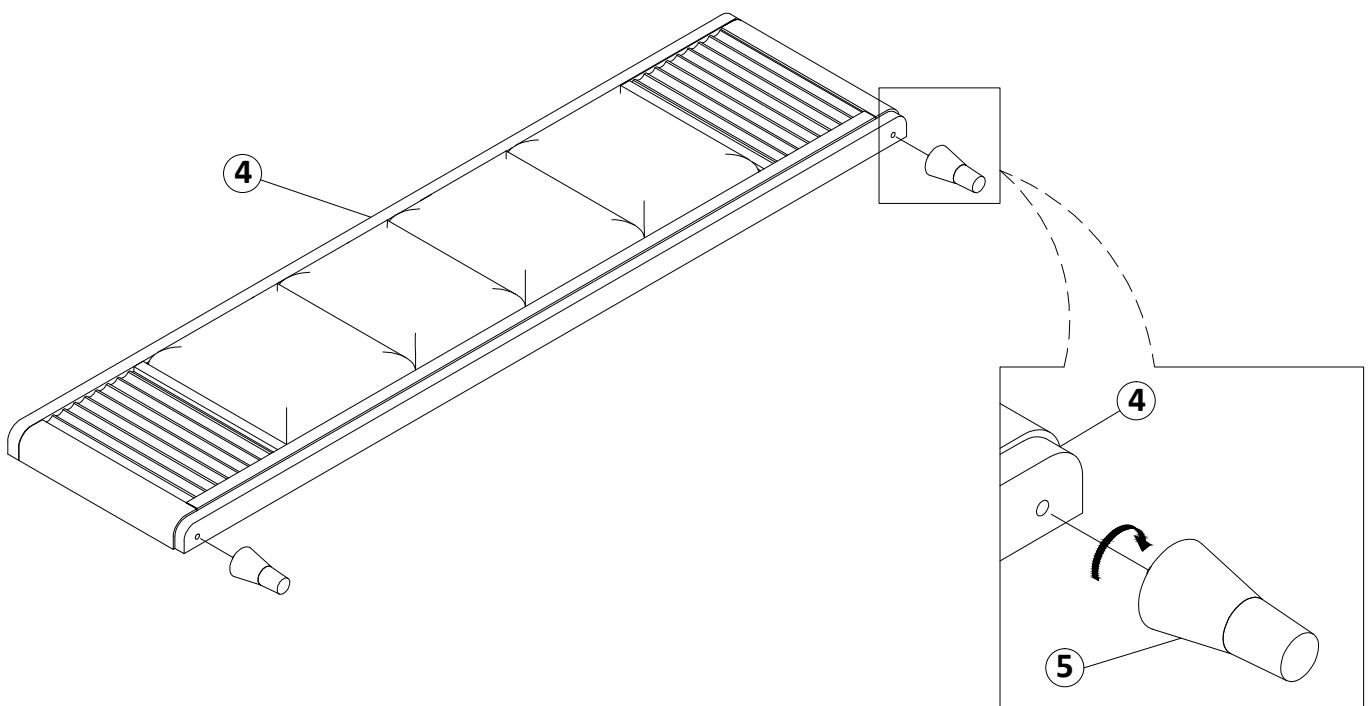

**THE HARDWARE IS LOCATED IN THE PACKING ITEMS.**

**NOTE: Periodically check to ensure that all connectors (bolts, screws, etc.) are tight.**

**NOTA: Verifique periódicamente que todos los conectores (tuercas, tornillos, etc.) esté bien apretados**

**ASSEMBLY INSTRUCTIONS**  
**INSTRUCCIONES**

**B1400-Q-HB/ B1400-Q-FB/ B1400-KQ-RAIL**  
**QUEEN BED**

**STEP 3**

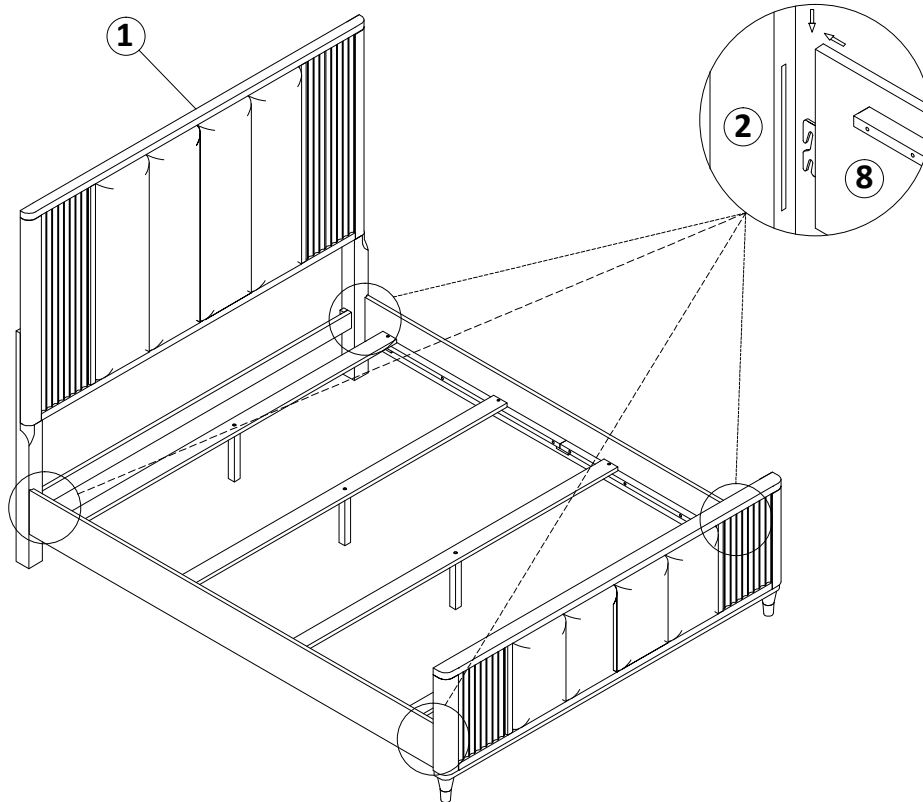

**STEP 4**

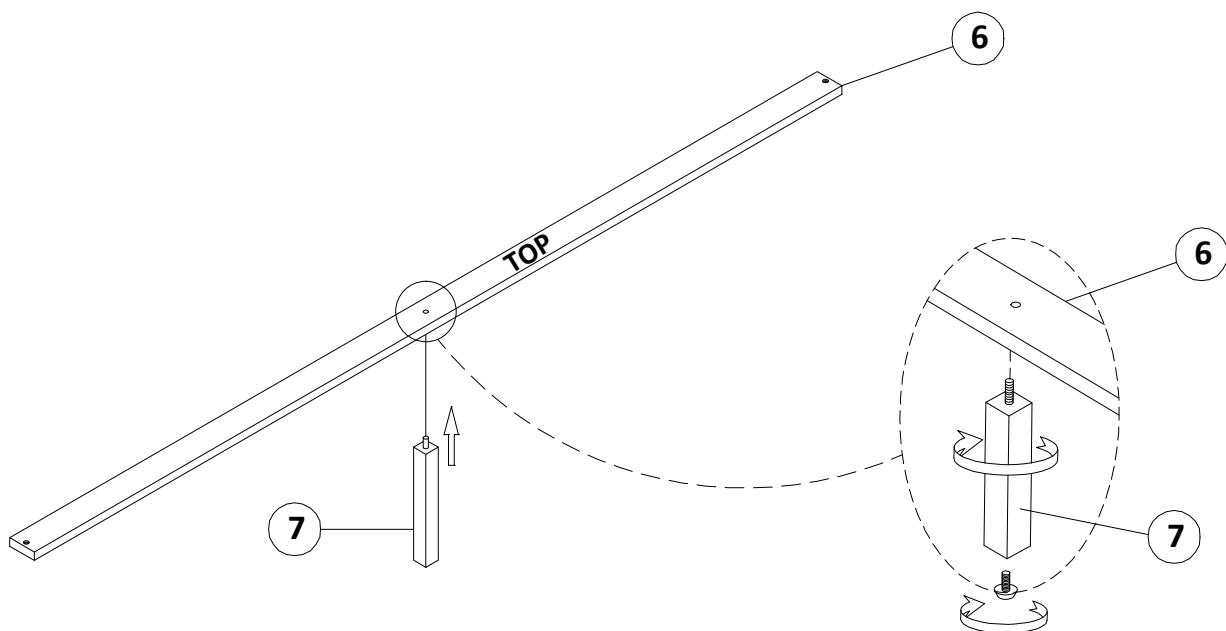

**THE HARDWARE IS LOCATED IN THE PACKING ITEMS.**

**NOTE: Periodically check to ensure that all connectors (bolts, screws, etc.) are tight.**

**NOTA: Verifique periódicamente que todos los conectores (tuercas, tornillos, etc.) esté bien apretados**

# ASSEMBLY INSTRUCTIONS INSTRUCCIONES

B1400-Q-HB/ B1400-Q-FB/ B1400-KQ-RAIL  
QUEEN BED

## STEP 5

**IMPORTANT**  
Make sure the **SCREW NUT** on wood  
slat (6) is **FACING UP** when  
assembling the support leg (7)

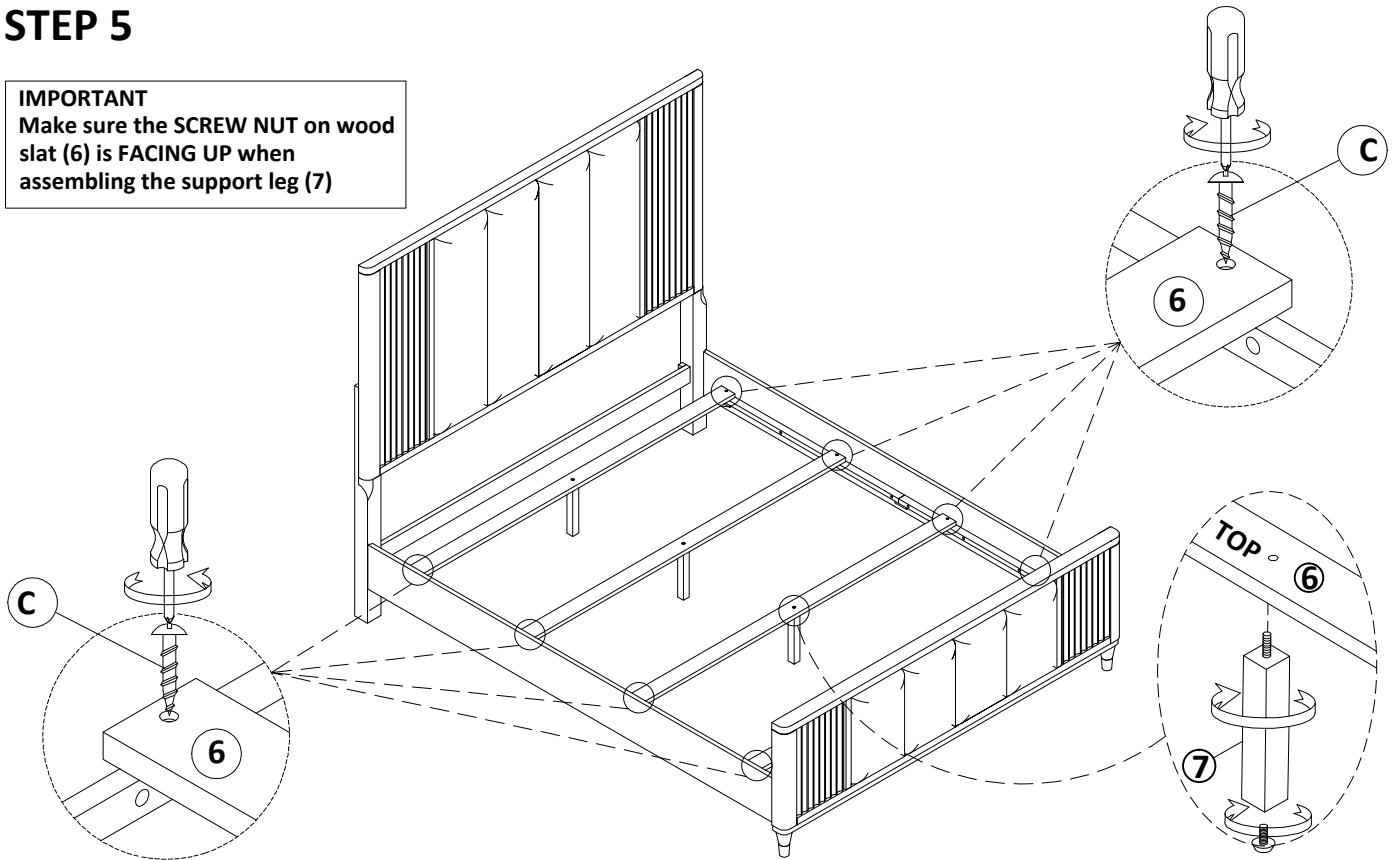

## STEP 6

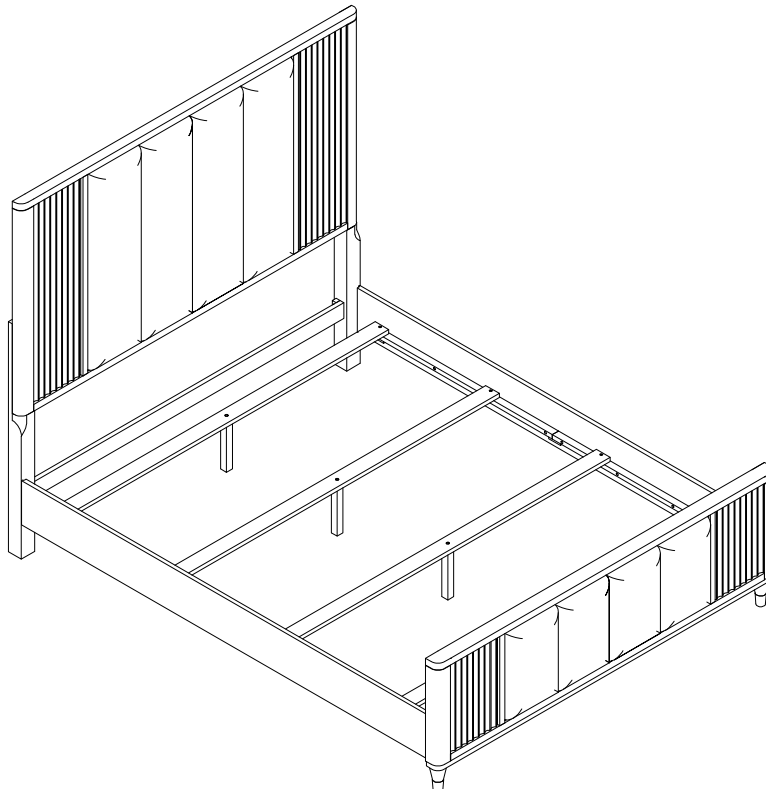

THE HARDWARE IS LOCATED IN THE PACKING ITEMS.

**NOTE:** Periodically check to ensure that all connectors (bolts, screws, etc.) are tight.

**NOTA:** Verifique periódicamente que todos los conectores (tuercas, tornillos, etc.) esté bien apretados