

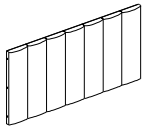
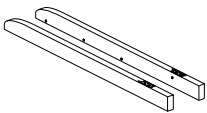
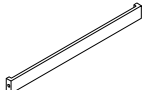

ASSEMBLY INSTRUCTIONS
INSTRUCCIONES

B1500-K-HB: KING HEADBOARD / CABECERA KING
 B1500-K-FB: KING FOOTBOARD / PIECERA KING
 B1500-KQ-RAIL: KING/QUEEN RAIL / RIEL PARA KING/QUEEN

BOX 1: BOX OF HEADBOARD

1		HEADBOARD	1
2		HEADBOARD LEG (L/R)	2
3		STRETCHER	1

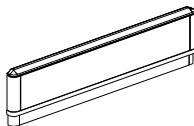

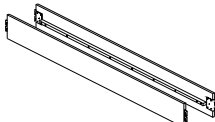

BOX 2: BOX OF FOOTBOARD

4		FOOTBOARD	1
5		BED SLAT	4
6		SUPPORT LEG	8

BOX 3: BOX OF RAILS

7		SIDE RAILS	2
---	---	------------	---

HARDWARE LIST
LISTA DE HARDWARE

A		BOLT Ø5/16" x 18 x 1-3/4"	8PCS/ PIEZAS
B		LOCK WASHER Ø5/16"	8PCS/ PIEZAS
C		FLAT WASHER Ø5/16" x 3/4"	8PCS/ PIEZAS
D		ALLEN WRENCH 5mm	1PC/ PIEZA
E		SCREW #8x1-1/4"	8PCS/ PIEZAS

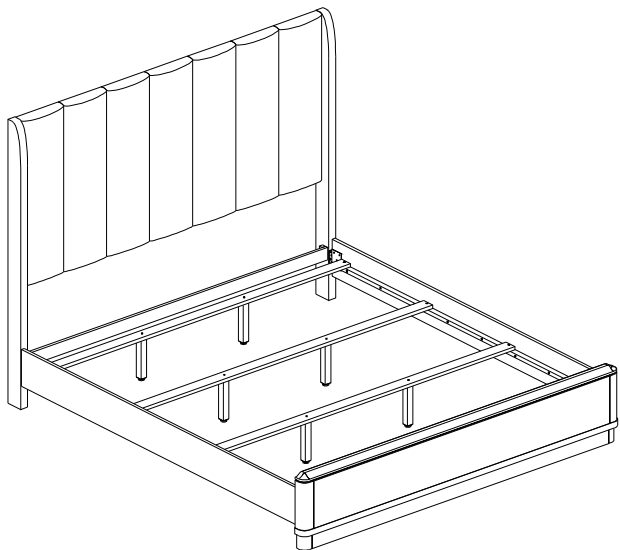
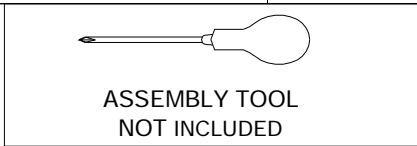

THE HARDWARE IS LOCATED
IN THE PACKING ITEMS.

NOTE:
DURING ASSEMBLY DO NOT FULLY
TIGHTEN ANY HARDWARE UNTIL THE
COMPLETE UNIT HAS BEEN ASSEMBLED.

ASSEMBLY INSTRUCTIONS
INSTRUCCIONES

B1500-K-HB: KING HEADBOARD / CABECERA KING
B1500-K-FB: KING FOOTBOARD / PIECERA KING
B1500-KQ-RAIL: KING/QUEEN RAIL / RIEL PARA KING/QUEEN

STEP 1

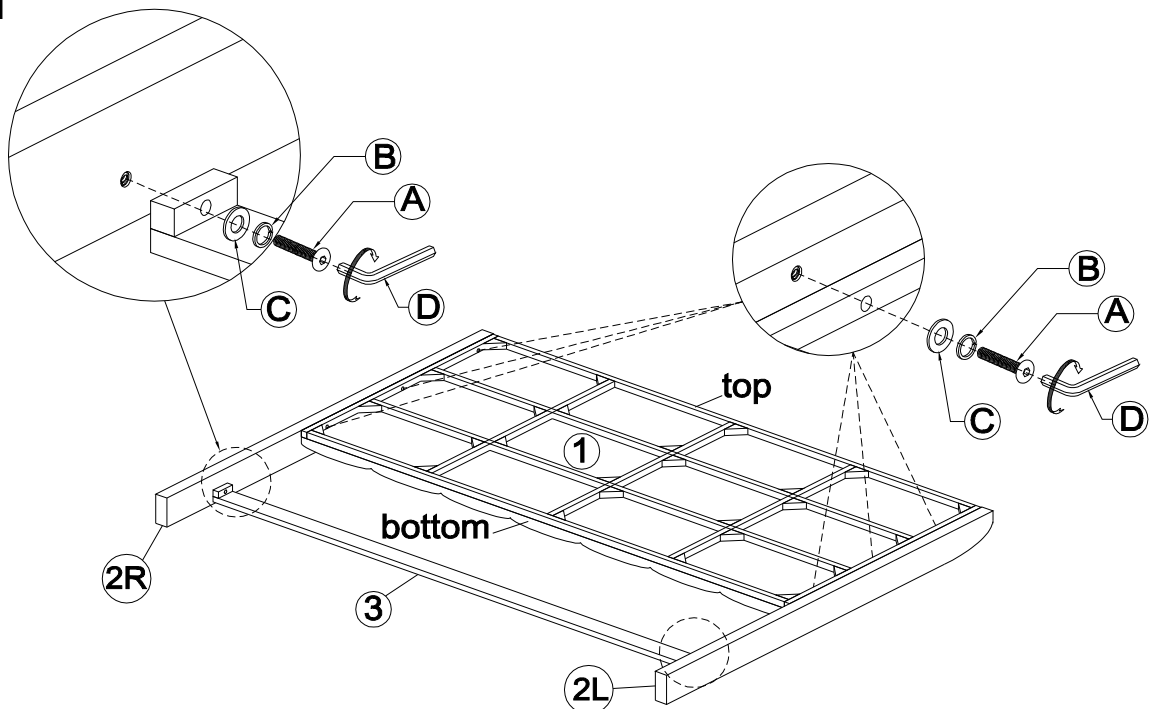

STEP 2

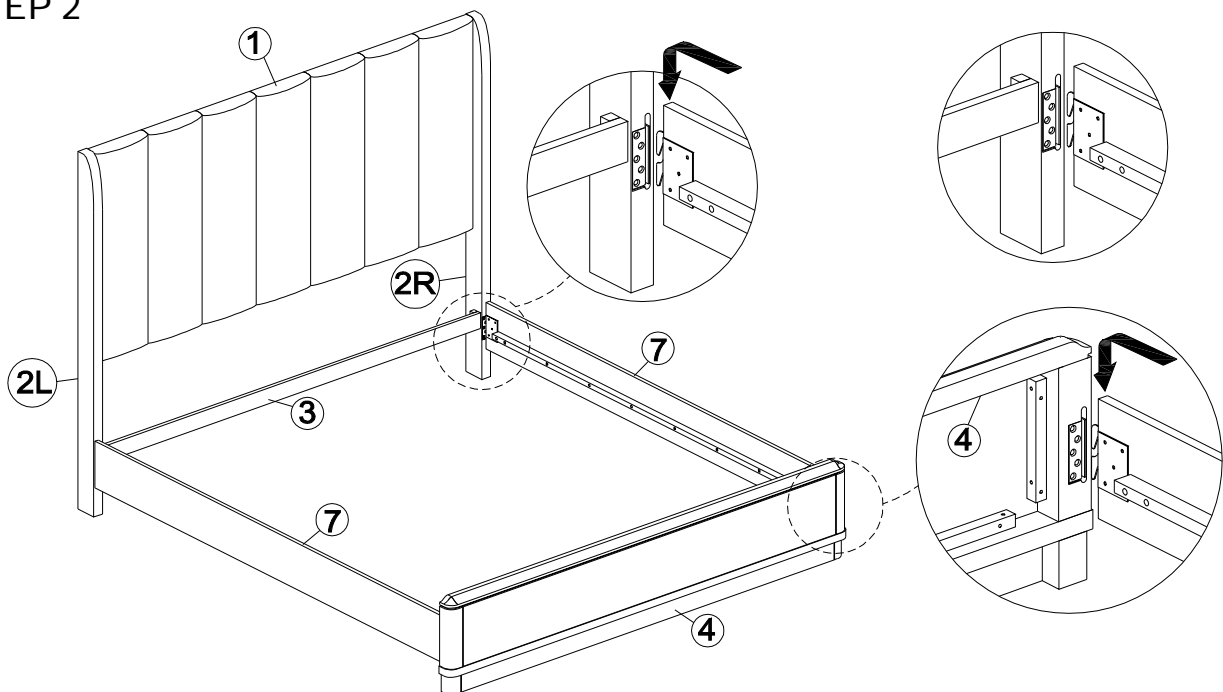

THE HARDWARE IS LOCATED
IN THE PACKING ITEMS.

NOTE:
DURING ASSEMBLY DO NOT FULLY
TIGHTEN ANY HARDWARE UNTIL THE
COMPLETE UNIT HAS BEEN ASSEMBLED.

ASSEMBLY INSTRUCTIONS
INSTRUCCIONES

B1500-K-HB: KING HEADBOARD / CABECERA KING
B1500-K-FB: KING FOOTBOARD / PIECERA KING
B1500-KQ-RAIL: KING/QUEEN RAIL / RIEL PARA KING/QUEEN

STEP 3

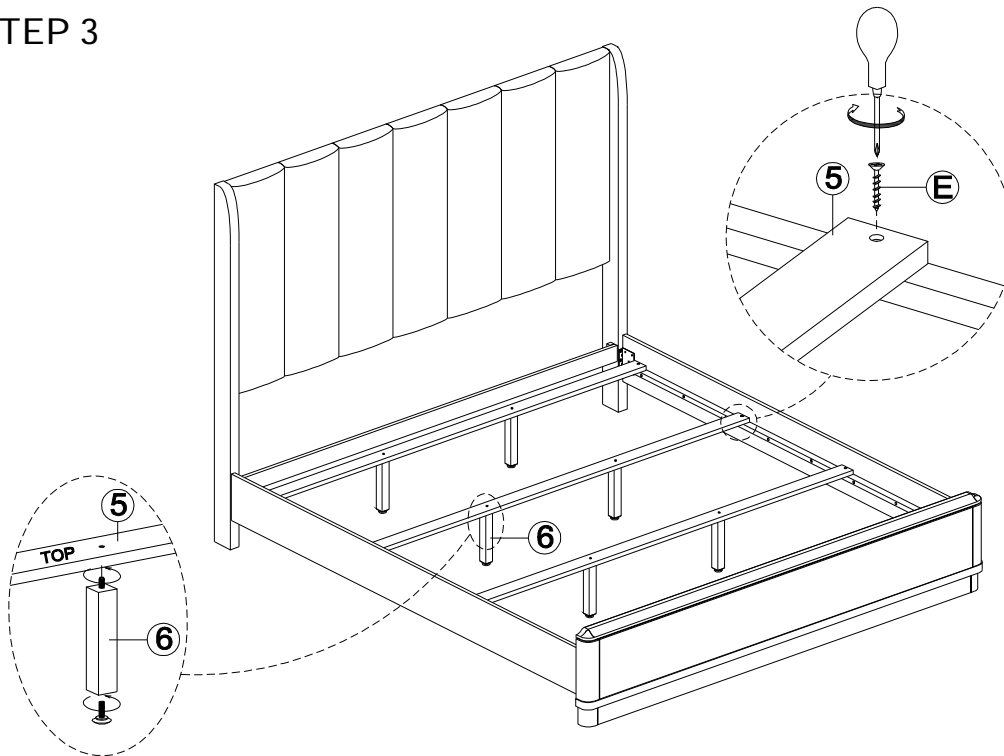

STEP 4

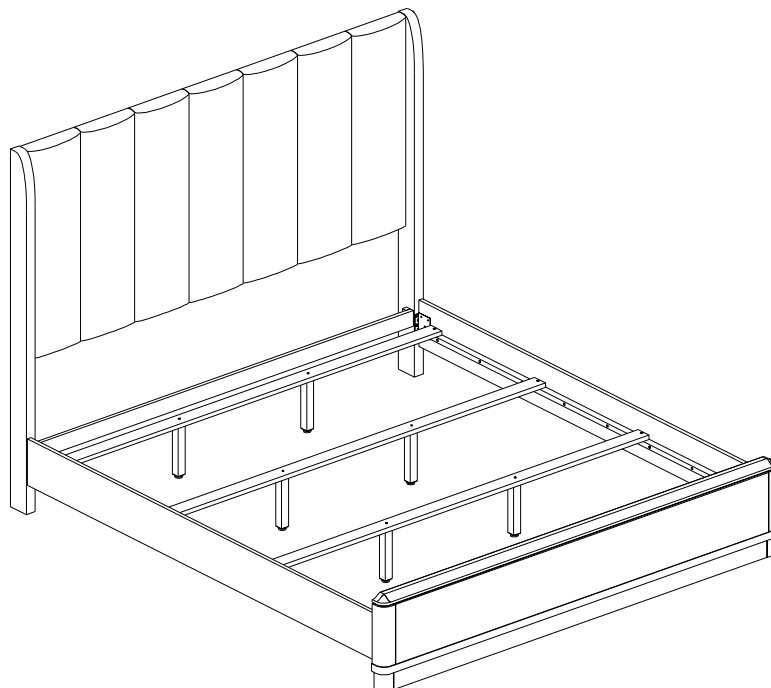

THE HARDWARE IS LOCATED
IN THE PACKING ITEMS.

NOTE:
DURING ASSEMBLY DO NOT FULLY
TIGHTEN ANY HARDWARE UNTIL THE
COMPLETE UNIT HAS BEEN ASSEMBLED.