

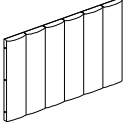
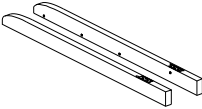
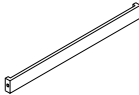
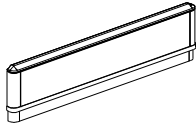

**ASSEMBLY INSTRUCTIONS**  
**INSTRUCCIONES**

B1500-Q-HB: QUEEN HEADBOARD / CABECERA QUEEN  
B1500-Q-FB: QUEEN FOOTBOARD / PIECERA QUEEN  
B1500-KQ-RAIL: KING/QUEEN RAIL / RIEL PARA KING/QUEEN

BOX 1: BOX OF HEADBOARD			
1		HEADBOARD	1
2		HEADBOARD LEG (L/R)	2
3		STRETCHER	1
BOX 2: BOX OF FOOTBOARD			
4		FOOTBOARD	1
5		BED SLAT	4
6		SUPPORT LEG	4
BOX 3: BOX OF RAILS			
7		SIDE RAILS	2

HARDWARE LIST LISTA DE HARDWARE			
A		BOLT Ø5/16" x 18 x 1-3/4"	8PCS/ PIEZAS
B		LOCK WASHER Ø5/16"	8PCS/ PIEZAS
C		FLAT WASHER Ø5/16" x 3/4"	8PCS/ PIEZAS
D		ALLEN WRENCH 5mm	1PC/ PIEZA
E		SCREW #8x1-1/4"	8PCS/ PIEZAS

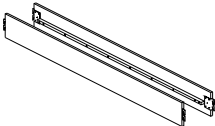
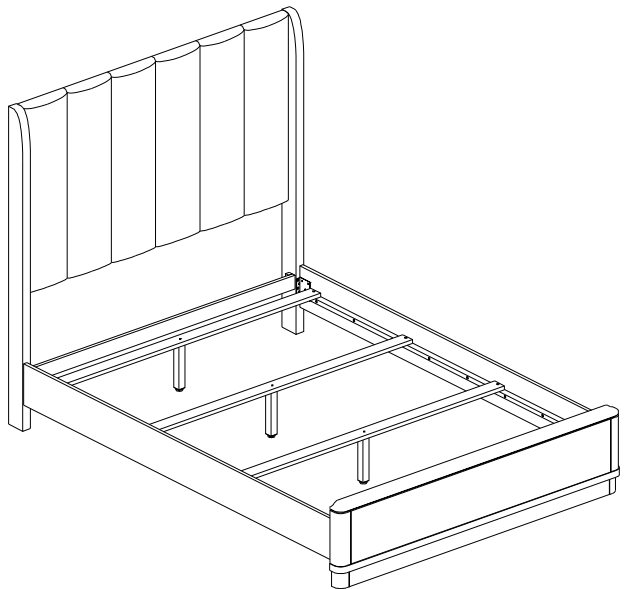
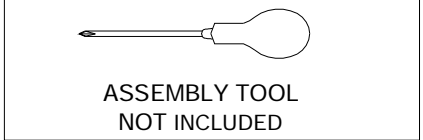

THE HARDWARE IS LOCATED IN THE PACKING ITEMS.

NOTE: DURING ASSEMBLY DO NOT FULLY TIGHTEN ANY HARDWARE UNTIL THE COMPLETE UNIT HAS BEEN ASSEMBLED.

ASSEMBLY INSTRUCTIONS  
INSTRUCCIONES

B1500-Q-HB: QUEEN HEADBOARD / CABECERA QUEEN  
B1500-Q-FB: QUEEN FOOTBOARD / PIECERA QUEEN  
B1500-KQ-RAIL: KING/QUEEN RAIL / RIEL PARA KING/QUEEN

STEP 1

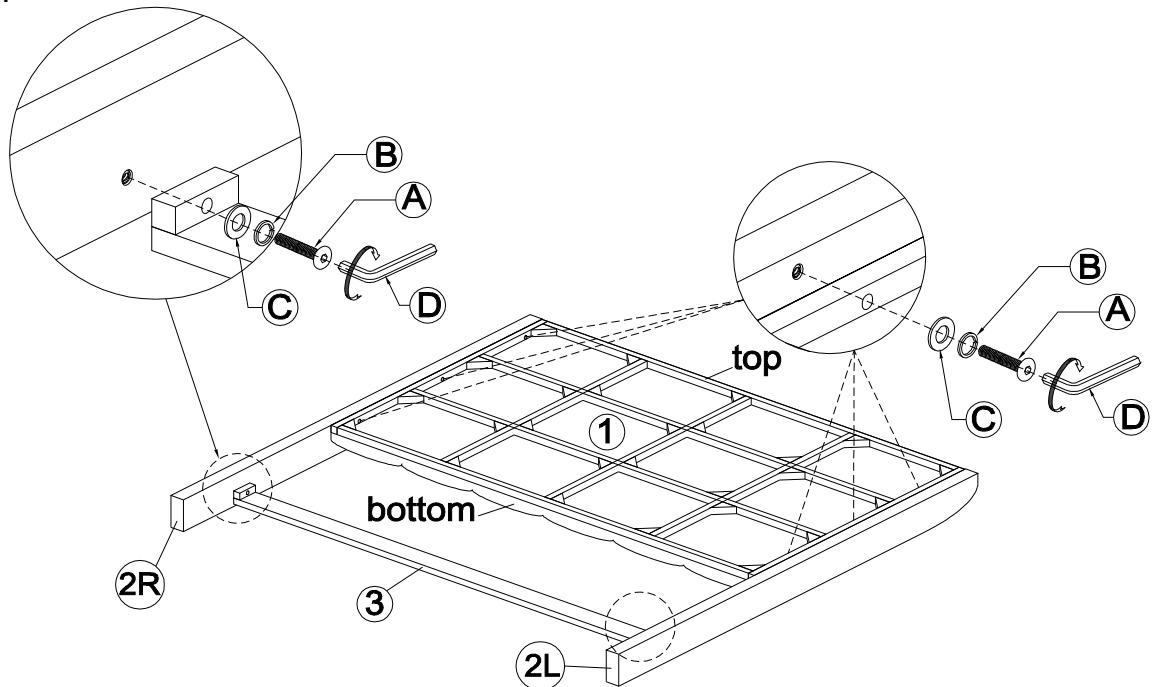

STEP 2

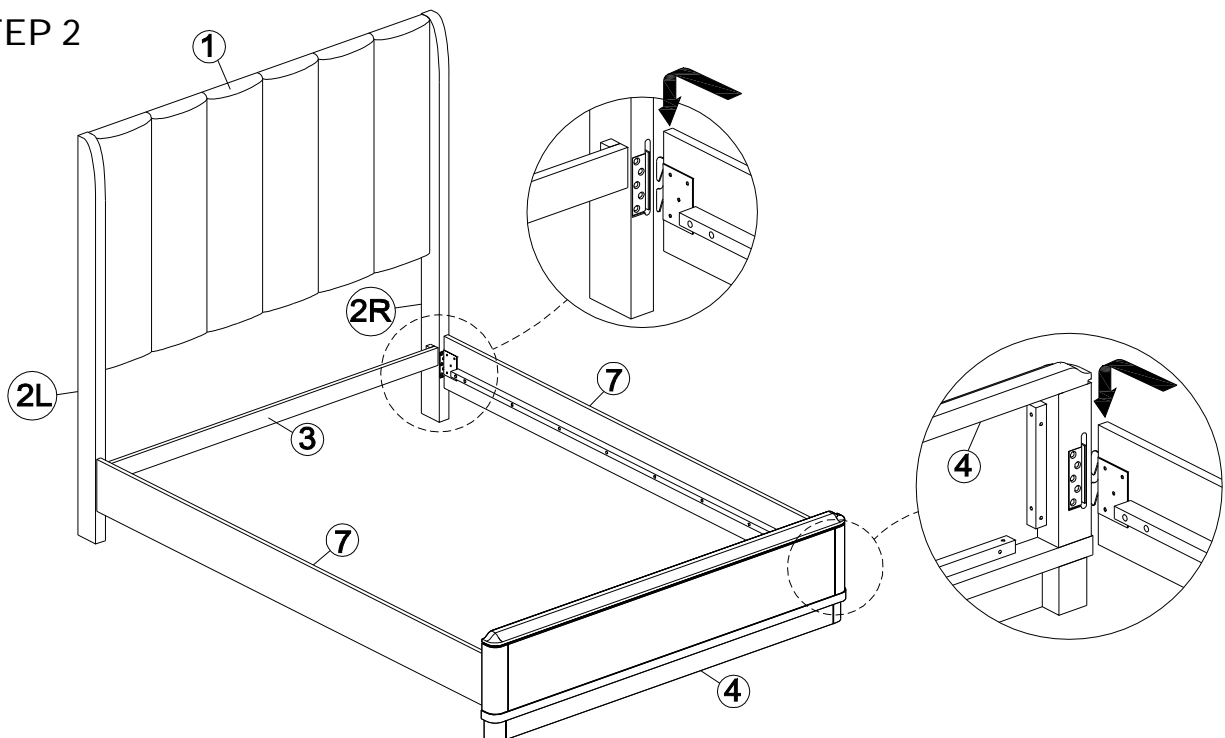

THE HARDWARE IS LOCATED  
IN THE PACKING ITEMS.

NOTE:  
DURING ASSEMBLY DO NOT FULLY  
TIGHTEN ANY HARDWARE UNTIL THE  
COMPLETE UNIT HAS BEEN ASSEMBLED.

ASSEMBLY INSTRUCTIONS  
INSTRUCCIONES

B1500-Q-HB: QUEEN HEADBOARD / CABECERA QUEEN  
B1500-Q-FB: QUEEN FOOTBOARD / PIECERA QUEEN  
B1500-KQ-RAIL: KING/QUEEN RAIL / RIEL PARA KING/QUEEN

STEP 3

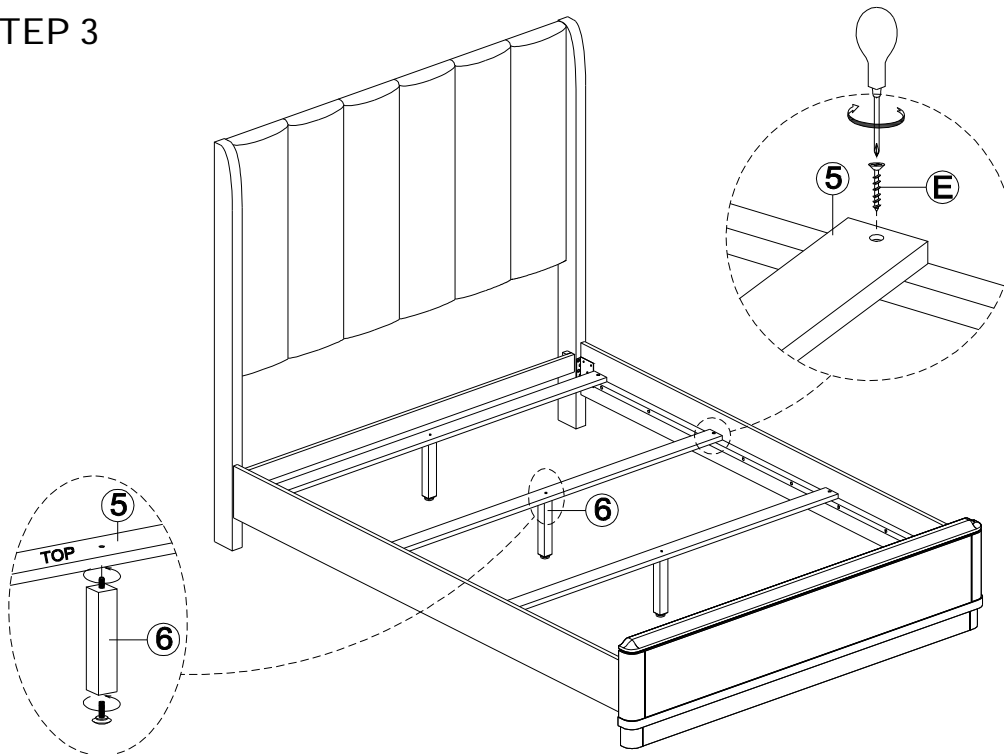

STEP 4

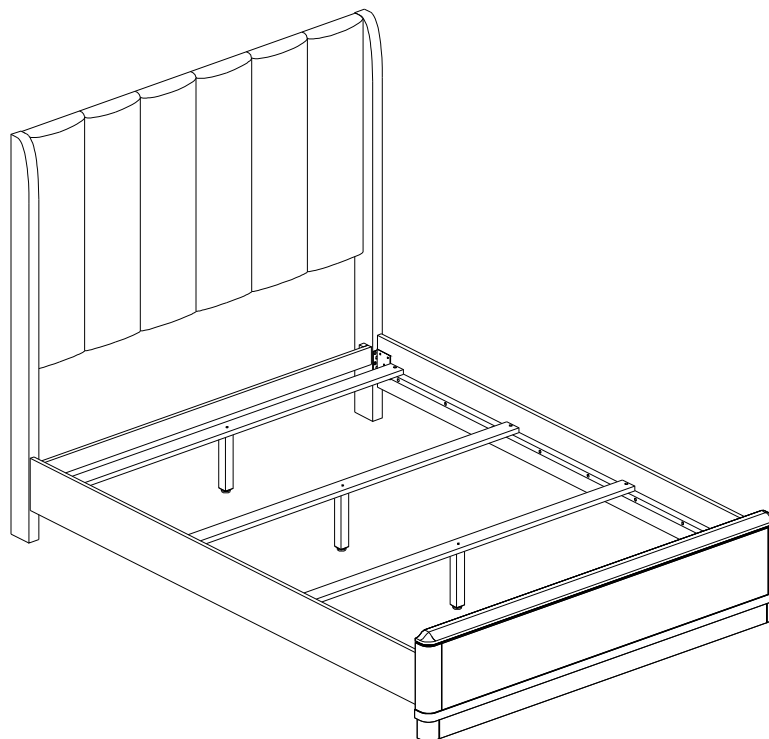

THE HARDWARE IS LOCATED  
IN THE PACKING ITEMS.

NOTE:  
DURING ASSEMBLY DO NOT FULLY  
TIGHTEN ANY HARDWARE UNTIL THE  
COMPLETE UNIT HAS BEEN ASSEMBLED.