







ASSEMBLY INSTRUCTION

B1600B-K-HB/ B1600B-K-FB/ B1600B-KQ-HBLEG/ B1600B-KQ-RAIL KING BED B1610-K-HB/ B1610-K-FB/ B1610-KQ-HBLEG/ B1610-KQ-RAIL KING BED

(BOX 1)
BOX OF HEADBOARD

NO	ITEM	QTY
A	Headboard 	1 PC
B	Finial 	1 PC
C	Stretcher 	1 PC

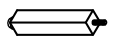

(BOX 2)
BOX OF FOOTBOARD

NO	ITEM	QTY
F	Footboard 	1 PC
G	Bed slat 	4 PCS
H	Support leg 	8 PCS
I	Bun foot 	2 PCS

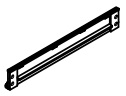





(BOX 3)
BOX OF SIDE RAIL

NO	ITEM	QTY
K	Side Rail 	2 PCS

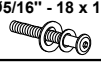
(BOX 4)
BOX OF HEADBOARD LEG

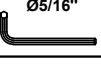
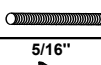
NO	ITEM	QTY
D	Headboard KD Leg (L/R) 	2 PCS
E	Bun foot 	2 PCS

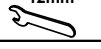
(BOX 1)
HARDWARE LIST

NO	ITEM	QTY
1	 Ø5/16" - 18 x 1-3/4" L	10 PCS
2	 Ø5/16" - 18 x 1-1/2" L	2 PCS
3	 Ø5/16"	1 PC
4	 Ø5/16" x 3-1/2" L	8 PCS
5	 5/16"	8 PCS
6	 5/16"	8 PCS
7	 12mm	1 PC
8	 1-3/16"	8 PCS
ASSEMBLY TOOL NOT INCLUDED 		

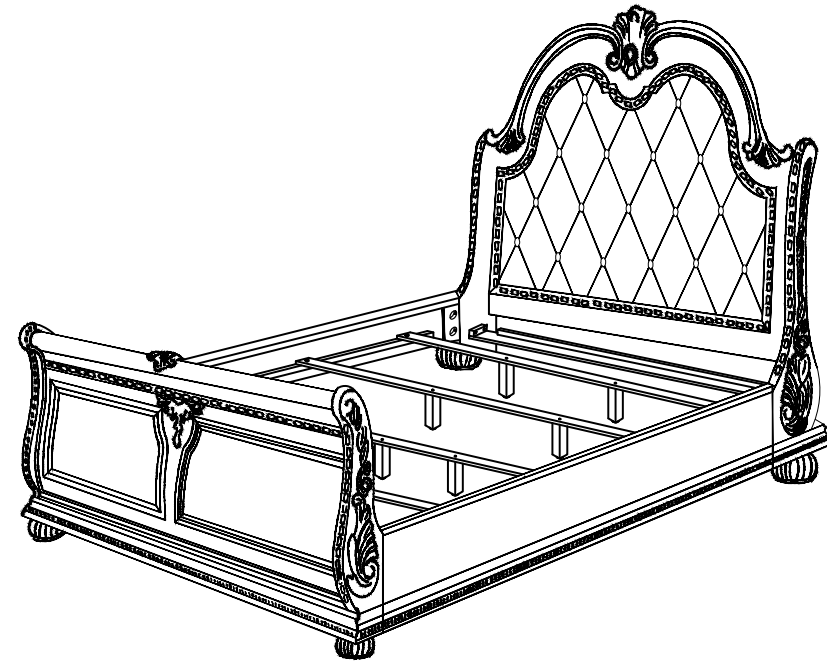

NOTE : DURING ASSEMBLY, DO NOT FULLY TIGHTEN ANY HARDWARE UNTIL THE COMPLETE UNIT HAS BEEN ASSEMBLED.

"THE HARDWARE IS LOCATED IN THE PACKING ITEMS"

NOTE: Periodically check to ensure that all connectors (bolts, screws, etc.) are tight.

NOTA: Verifique periódicamente que todos los conectores (tuercas, tornillos, etc.) estén bien apretados.

STEP 1

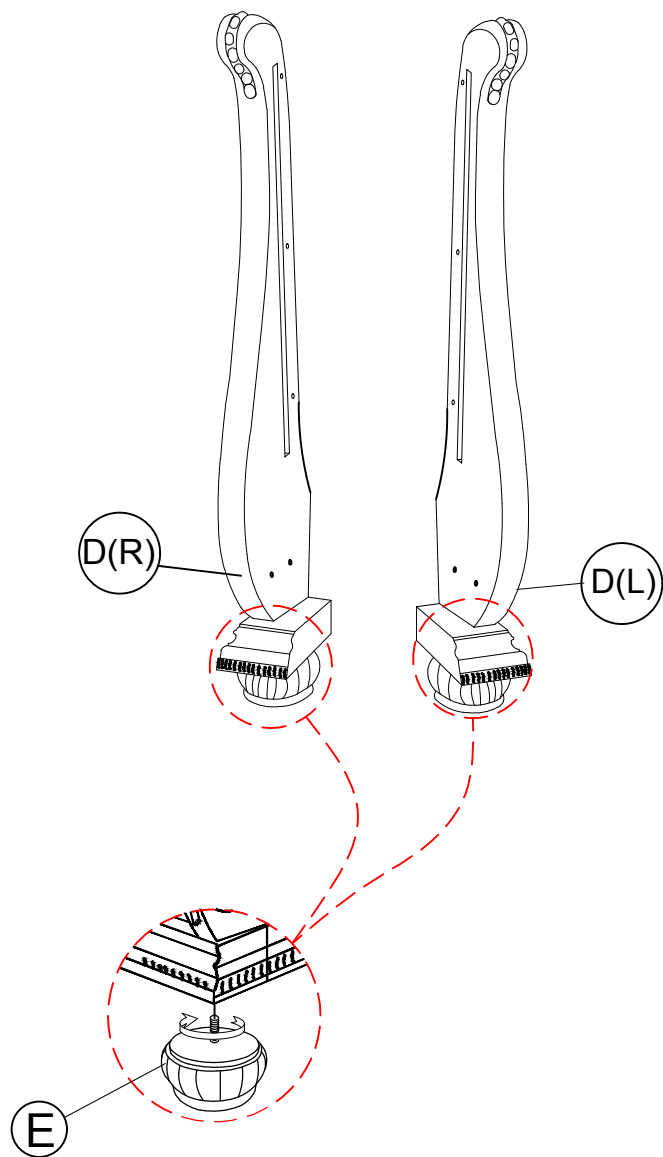

STEP 2

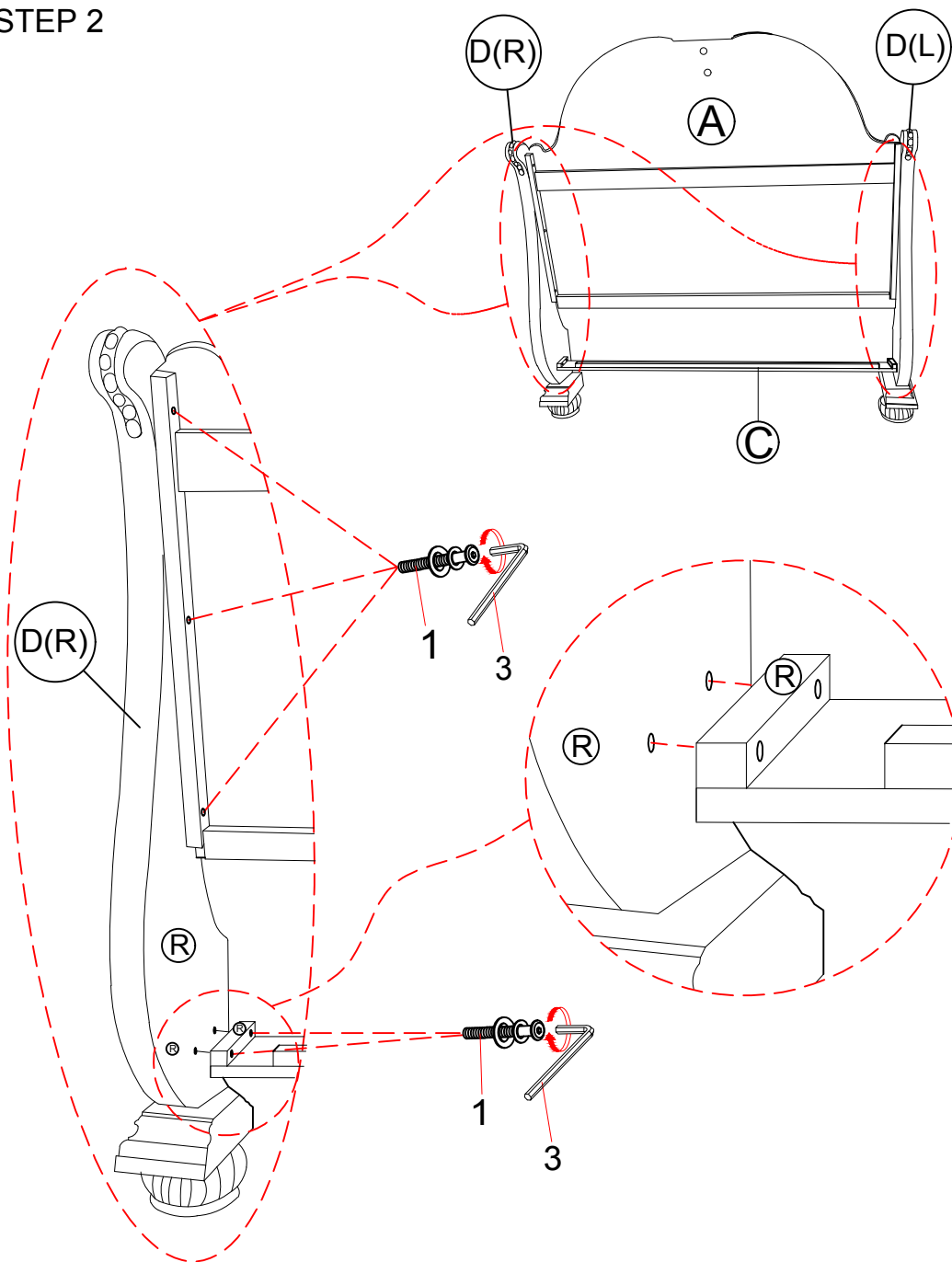

"THE HARDWARE IS LOCATED IN THE PACKING ITEMS"

NOTE: Periodically check to ensure that all connectors (bolts, screws, etc.) are tight.

NOTA: Verifique periódicamente que todos los conectores (tuercas, tornillos, etc.) estén bien apretados.

STEP 3

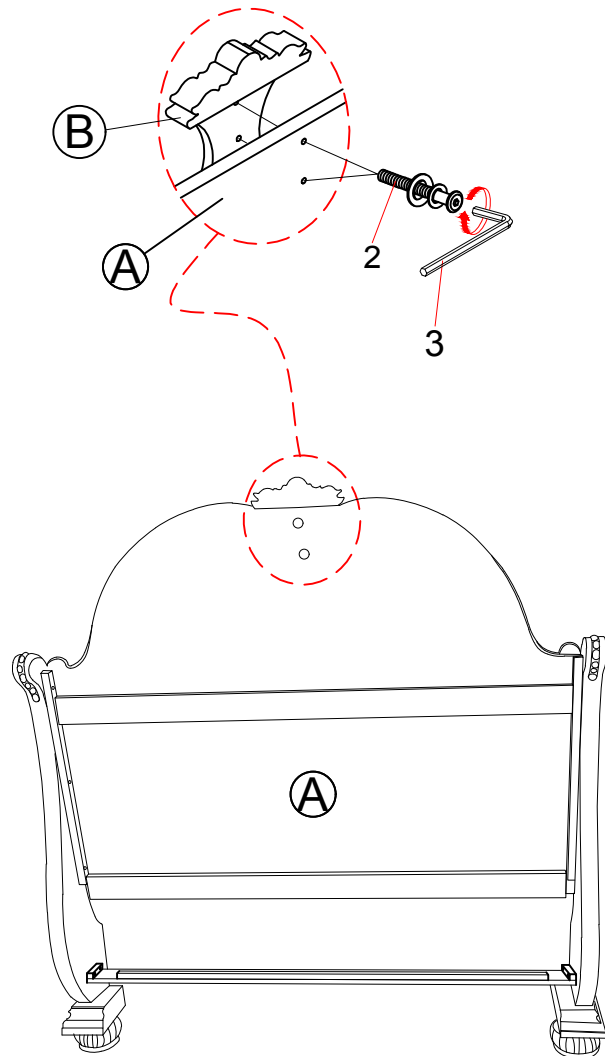

"THE HARDWARE IS LOCATED IN THE PACKING ITEMS"

STEP 4

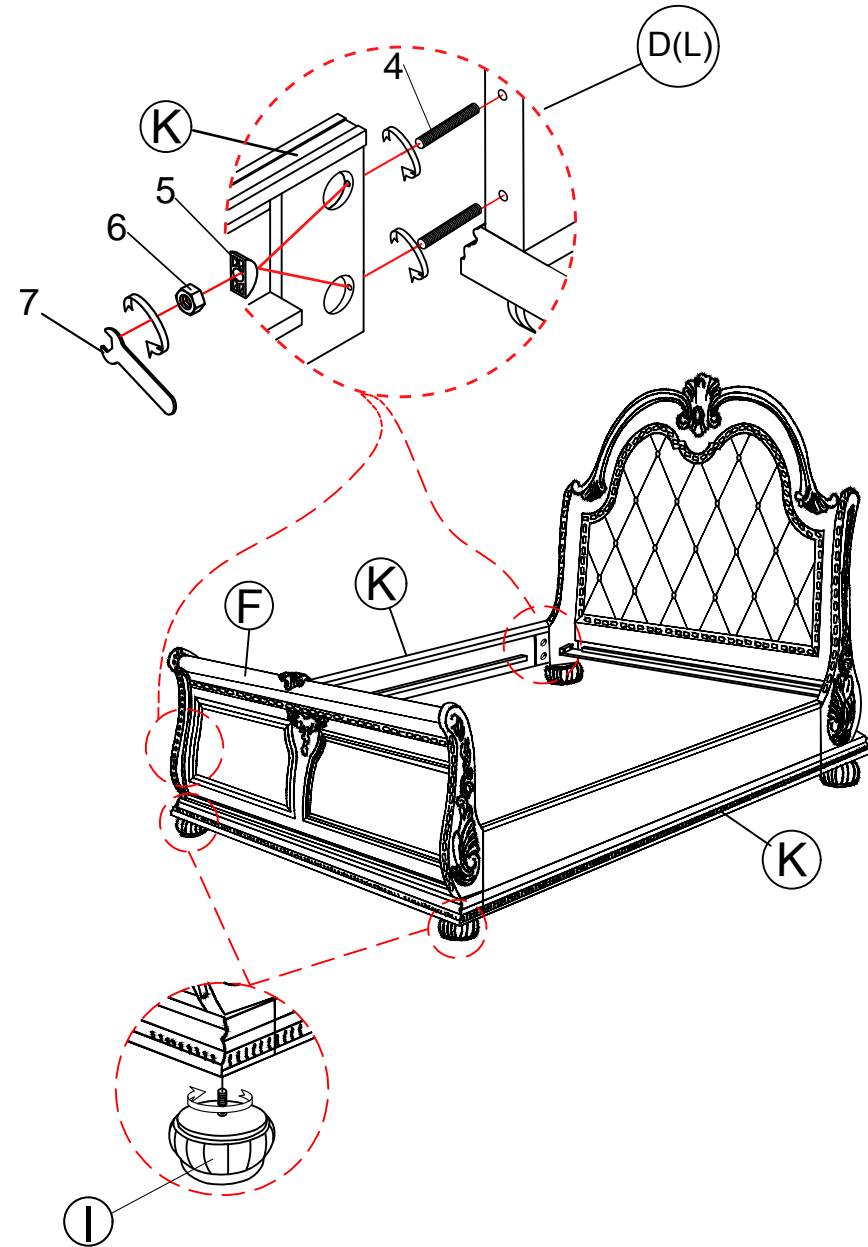

NOTE: Periodically check to ensure that all connectors (bolts, screws, etc.) are tight.

NOTA: Verifique periódicamente que todos los conectores (tuercas, tornillos, etc.) estén bien apretados.

STEP 5

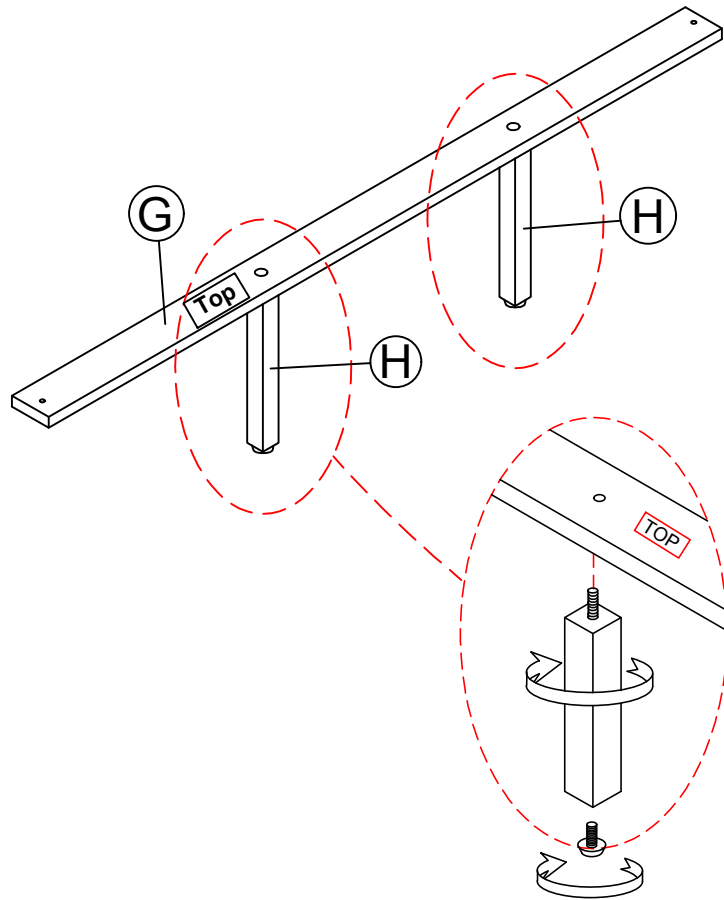

"THE HARDWARE IS LOCATED IN THE PACKING ITEMS"

STEP 6 COMPLETED

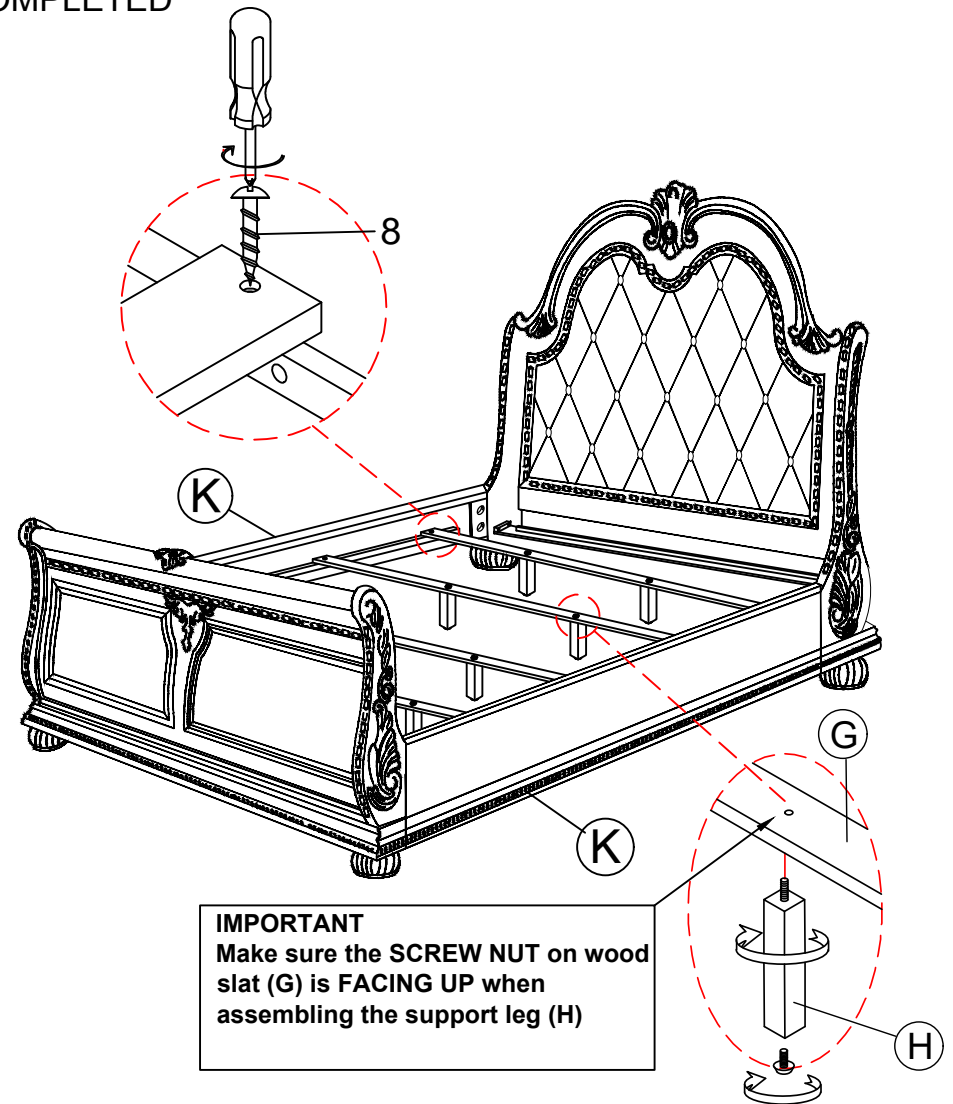

NOTE: Periodically check to ensure that all connectors (bolts, screws, etc.) are tight.

NOTA: Verifique periódicamente que todos los conectores (tuercas, tornillos, etc.) estén bien apretados.