

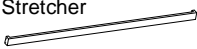



ASSEMBLY INSTRUCTIONS

B1640-Q-HB/B1640-Q-FB/B1640-KQ-HBLEG/ B1640-KQ-RAIL QUEEN BED

(BOX 1)
BOX OF HEADBOARD

NO	ITEM	QTY
A	Headboard 	1PC
B	Stretcher 	1PC

(BOX 2)
BOX OF FOOTBOARD

NO	ITEM	QTY
D	Footboard 	1PC
E	Slats 	4PCS
F	Support legs 	4PCS









(BOX 3)
BOX OF SIDE RAIL

NO	ITEM	QTY
G	Side rails 	2PCS

(BOX 4)
BOX OF HEADBOARD LEG

NO	ITEM	QTY
C	K/D Legs (L&R) 	2PCS

(BOX 1)
HARDWARE LIST

NO	ITEM	QTY
1	Ø5/16"-18 x 2" L 	10 SET
2	4mm 	1 PC
3	Ø5/16"X3-1/2" 	8 PCS
4	Ø5/16" 	8 PCS
5	Ø5/16" 	8 PCS
6	12mm 	1 PC
7	1-3/16" 	8 PCS
ASSEMBLY TOOL NOT INCLUDED		

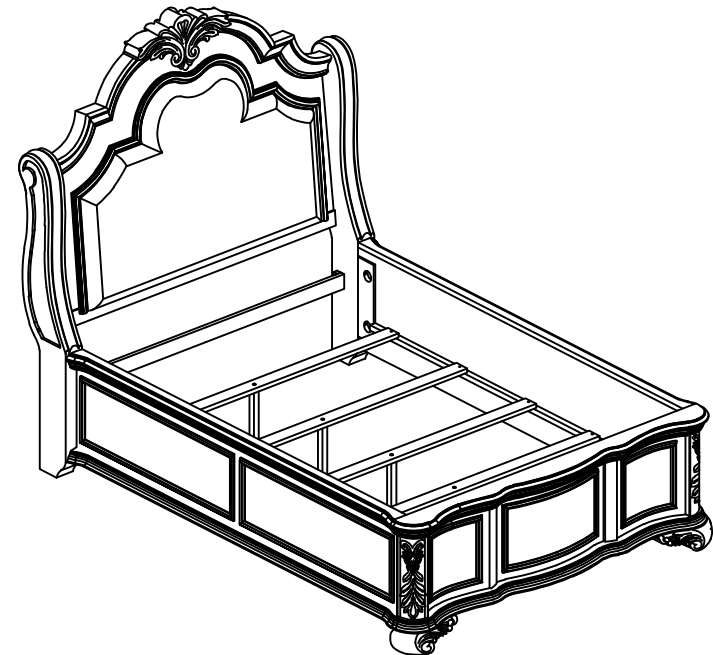

NOTE : DURING ASSEMBLY, DO NOT FULLY TIGHTEN
ANY HARDWARE UNTIL THE COMPLETE
UNIT HAS BEEN ASSEMBLED.

"THE HARDWARE IS LOCATED IN THE PACKING ITEMS"

NOTE: Periodically check to ensure that all connectors (bolts, screws, etc.) are tight.

NOTA: Verifique periódicamente que todos los conectores (tuercas, tornillos, etc.) estén bien apretados.

STEP 1

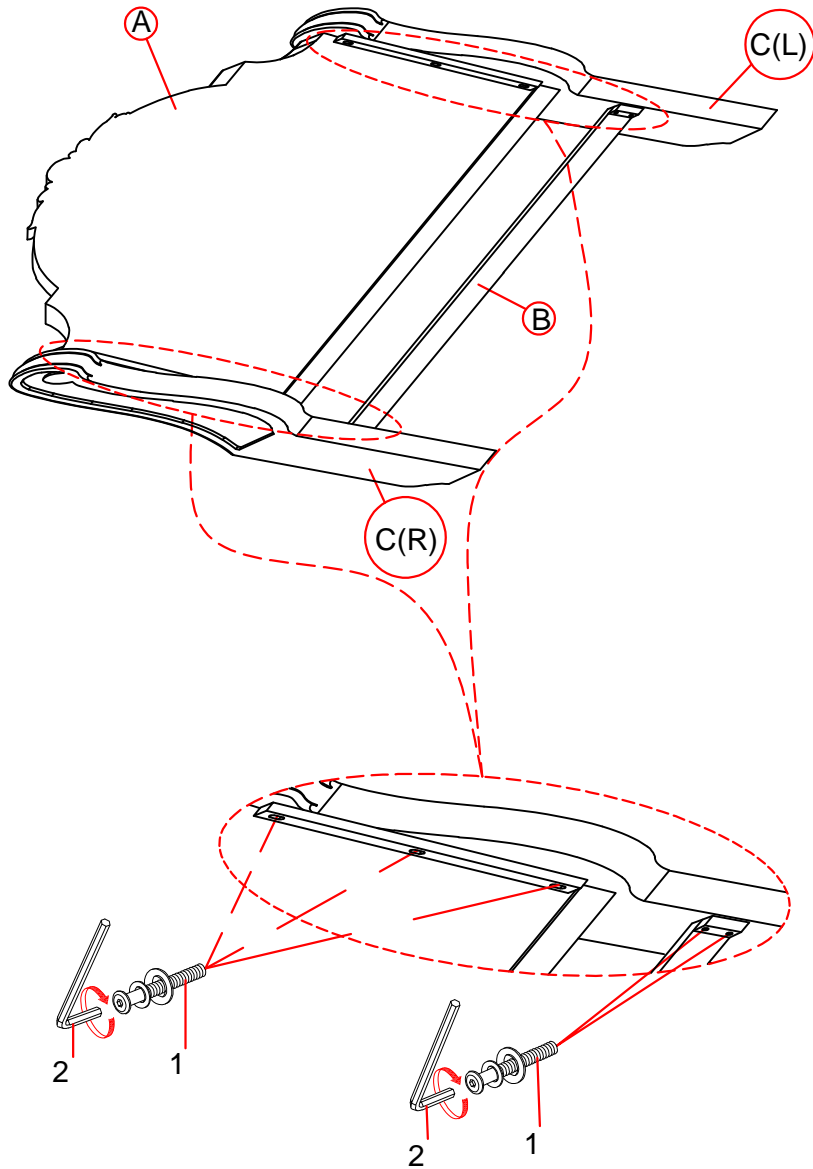

STEP 2

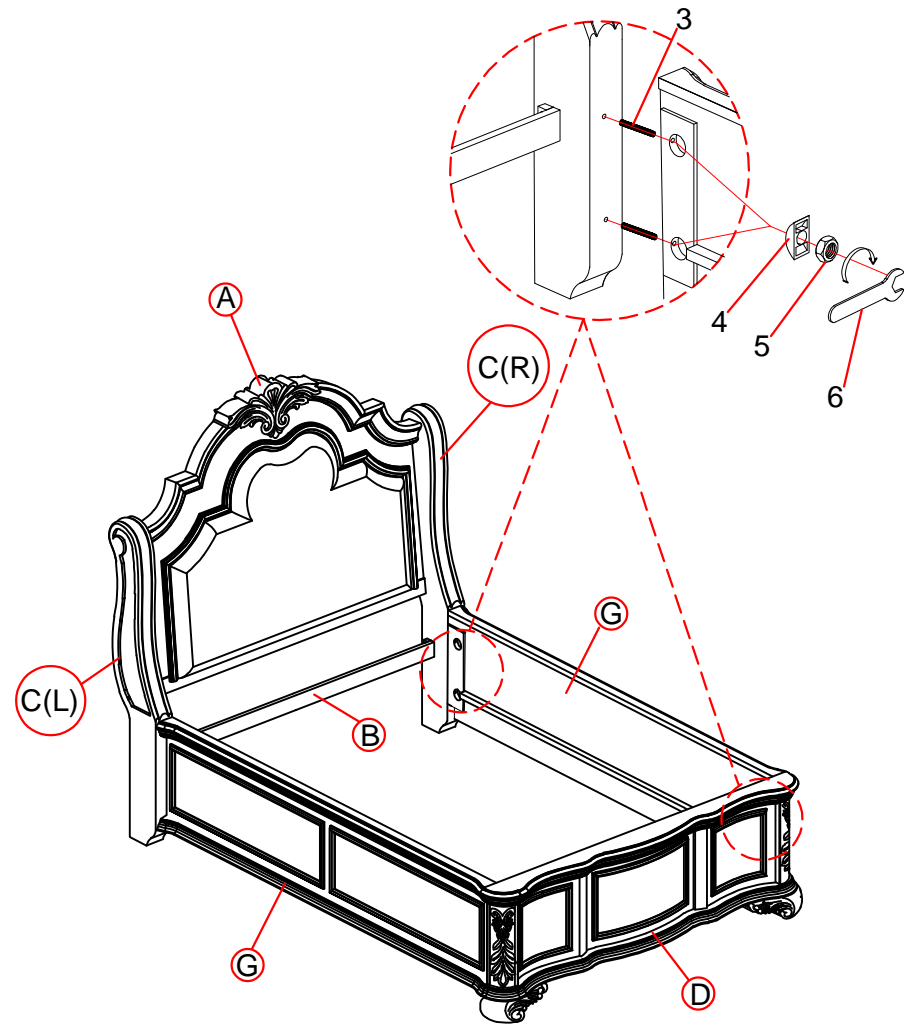

"THE HARDWARE IS LOCATED IN THE PACKING ITEMS"

NOTE: Periodically check to ensure that all connectors (bolts, screws, etc.) are tight.

NOTA: Verifique periódicamente que todos los conectores (tuercas, tornillos, etc.) estén bien apretados.

STEP 3

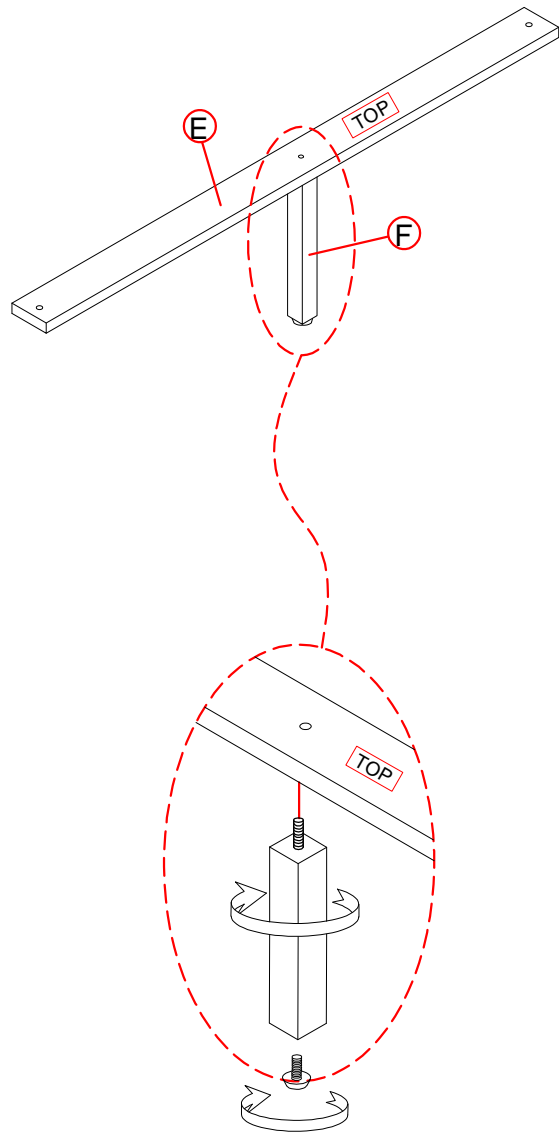

STEP 4

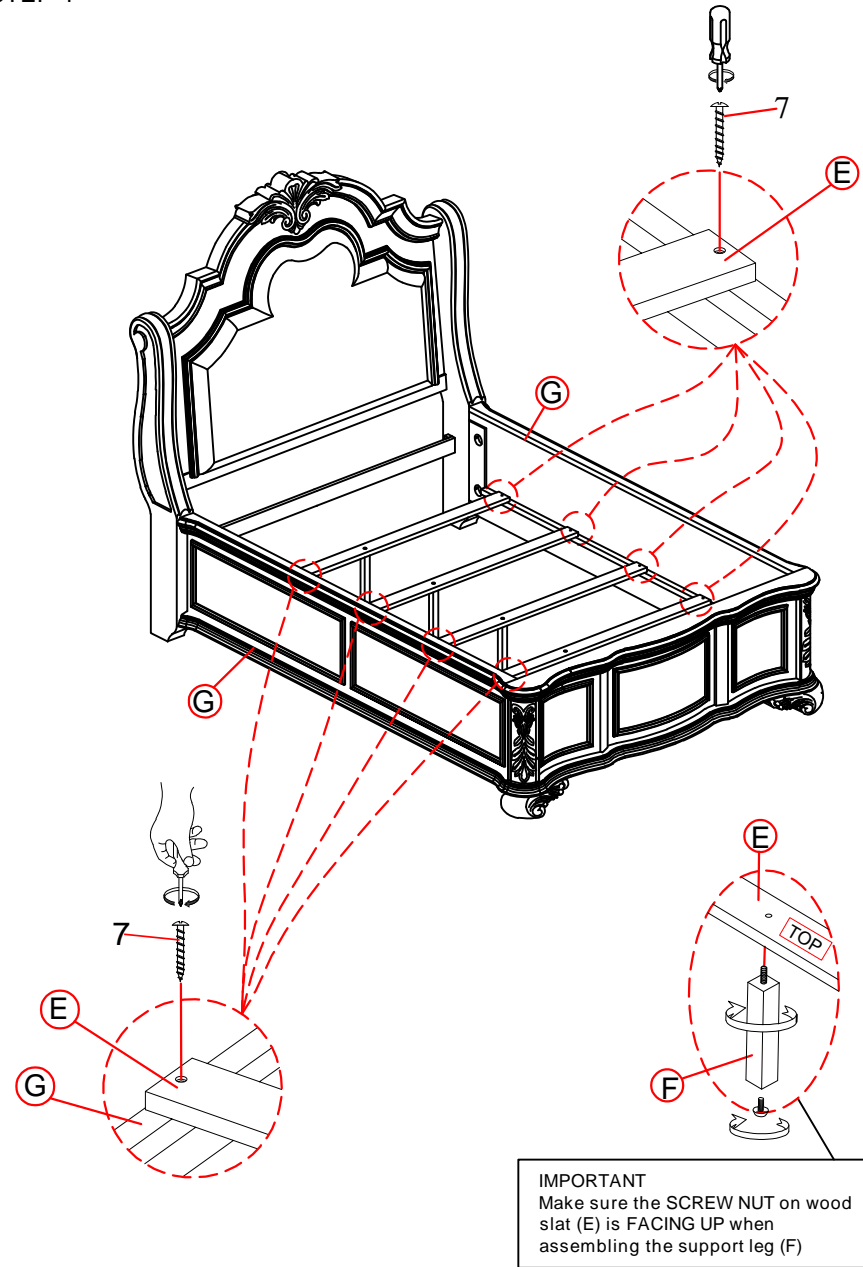

IMPORTANT
Make sure the **SCREW NUT** on wood slat (E) is **FACING UP** when assembling the support leg (F)

"THE HARDWARE IS LOCATED IN THE PACKING ITEMS"

NOTE: Periodically check to ensure that all connectors (bolts, screws, etc.) are tight.

NOTA: Verifique periódicamente que todos los conectores (tuercas, tornillos, etc.) estén bien apretados.