

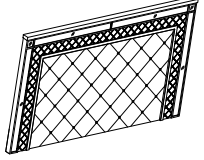

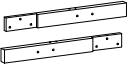



ASSEMBLY INSTRUCTIONS

B1670-Q-HB/ B1670-Q-FB/ B1670-KQ-RAIL QUEEN BED

(BOX 1)
BOX OF HEADBOARD

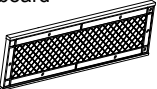
NO	ITEM	QTY
A	Headboard 	1PC
B	K/D Legs (L&R) 	2PCS
C	Stretcher 	1PC





(BOX 2)
BOX OF FOOTBOARD

NO	ITEM	QTY
D	Footboard 	1PC
E	Legs 	2PCS
F	Slats 	4PCS
G	Support legs 	4PCS

(BOX 3)
BOX OF SIDE RAIL

NO	ITEM	Q'TY
H	Side rails 	2PCS

(BOX 1)
HARDWARE LIST

NO	ITEM	QTY
1	Ø5/16"-18 x 2" L 	10 SET
2	4mm 	1 PC
3	1-3/16" 	8 PCS
ASSEMBLY TOOL NOT INCLUDED		

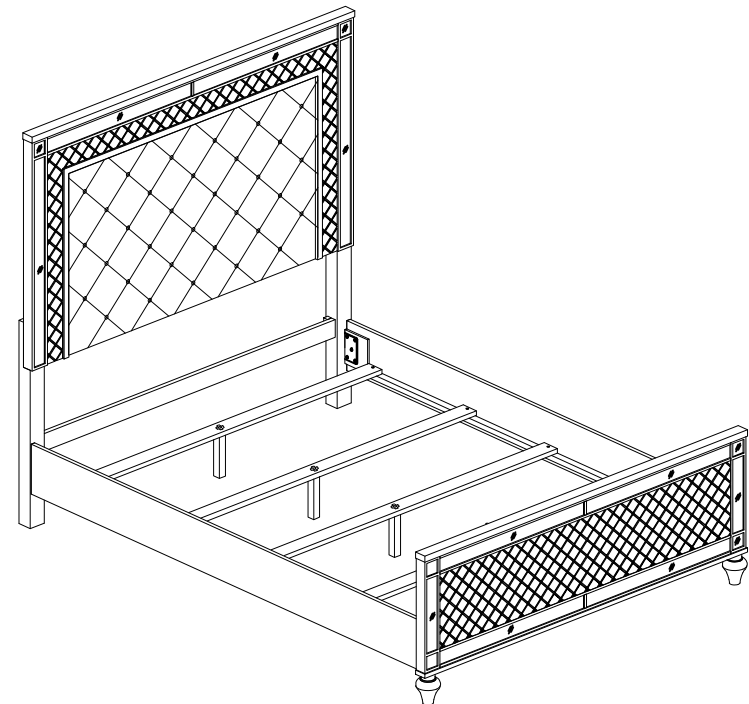

NOTE : DURING ASSEMBLY, DO NOT FULLY TIGHTEN ANY HARDWARE UNTIL THE COMPLETE UNIT HAS BEEN ASSEMBLED.

"THE HARDWARE IS LOCATED IN THE PACKING ITEMS"

NOTE: Periodically check to ensure that all connectors (bolts, screws, etc.) are tight.

NOTA: Verifique periódicamente que todos los conectores (tuercas, tornillos, etc.) estén bien apretados.

STEP 1

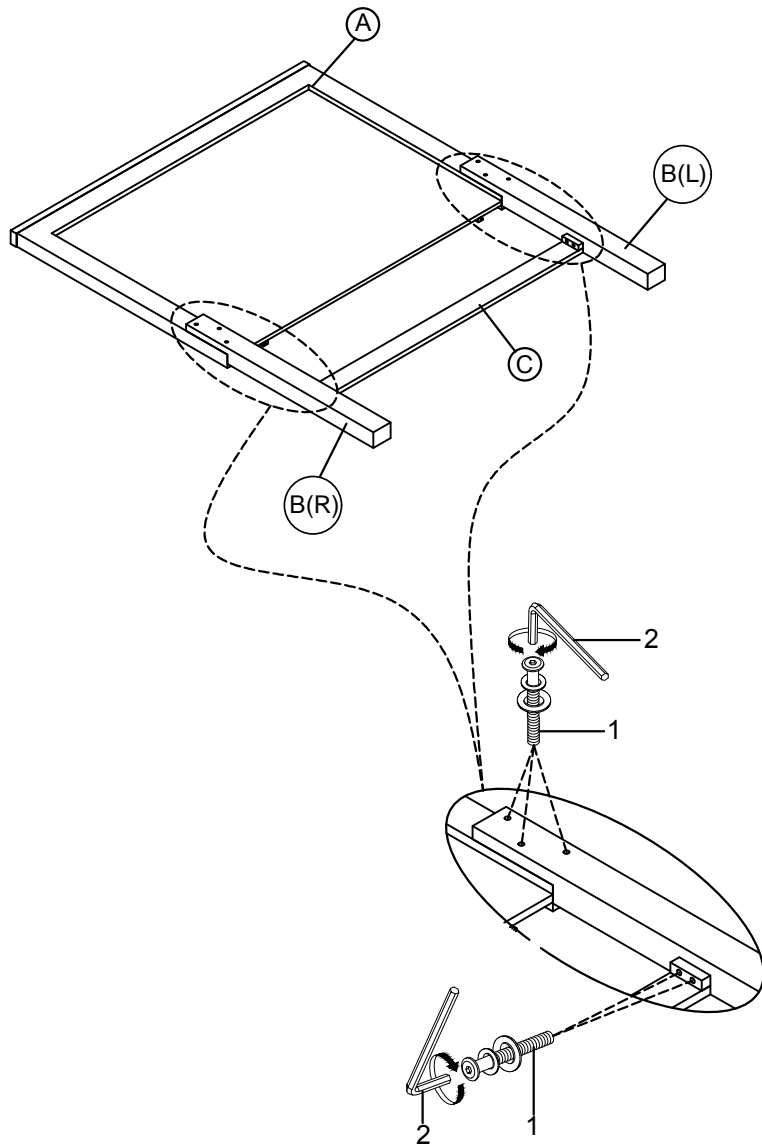

STEP 2

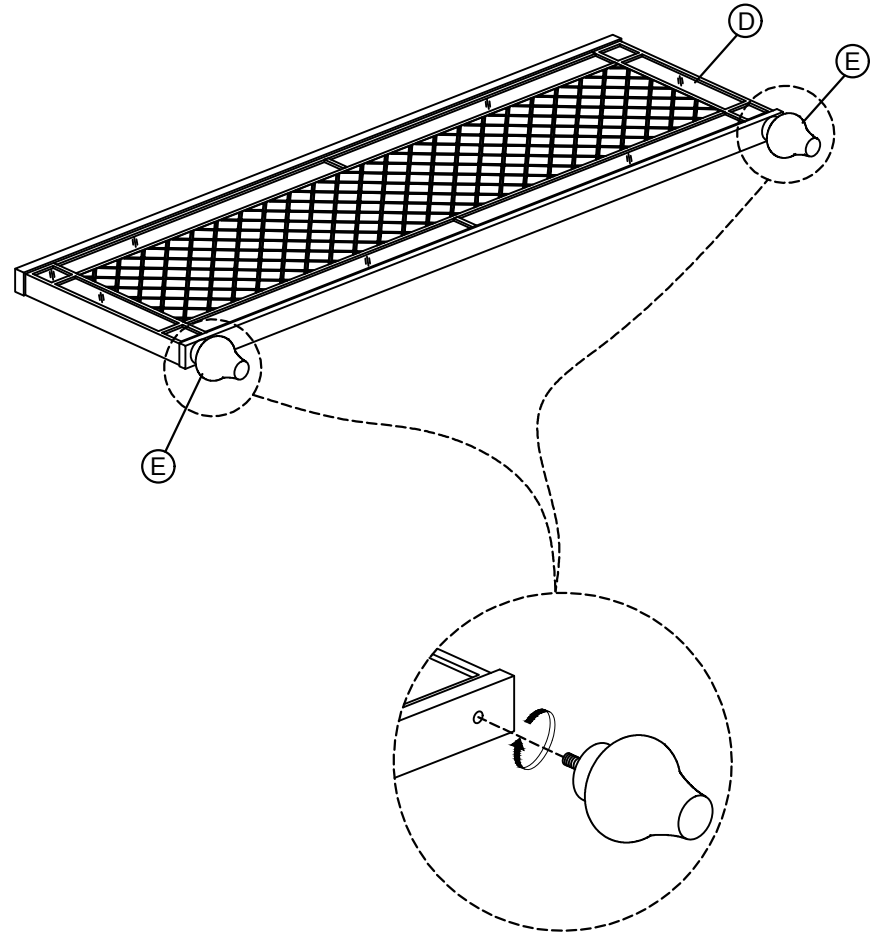

"THE HARDWARE IS LOCATED IN THE PACKING ITEMS"

NOTE: Periodically check to ensure that all connectors (bolts, screws, etc.) are tight.

NOTA: Verifique periódicamente que todos los conectores (tuercas, tornillos, etc.) estén bien apretados.

STEP 3

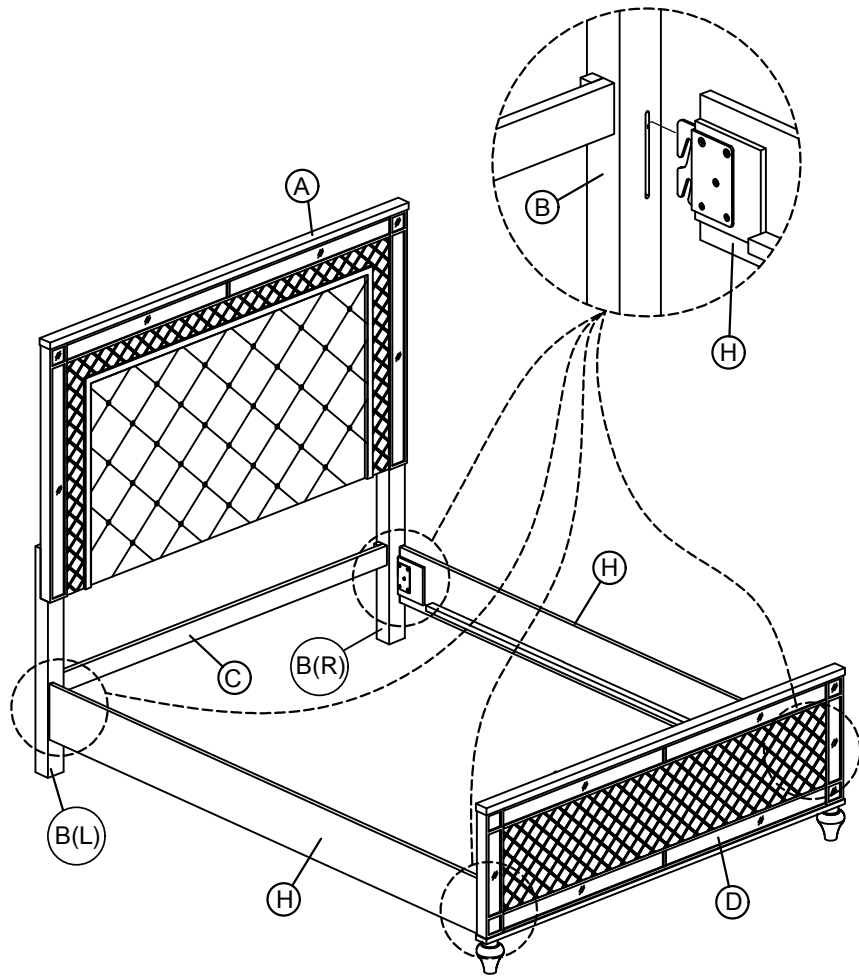

STEP 4

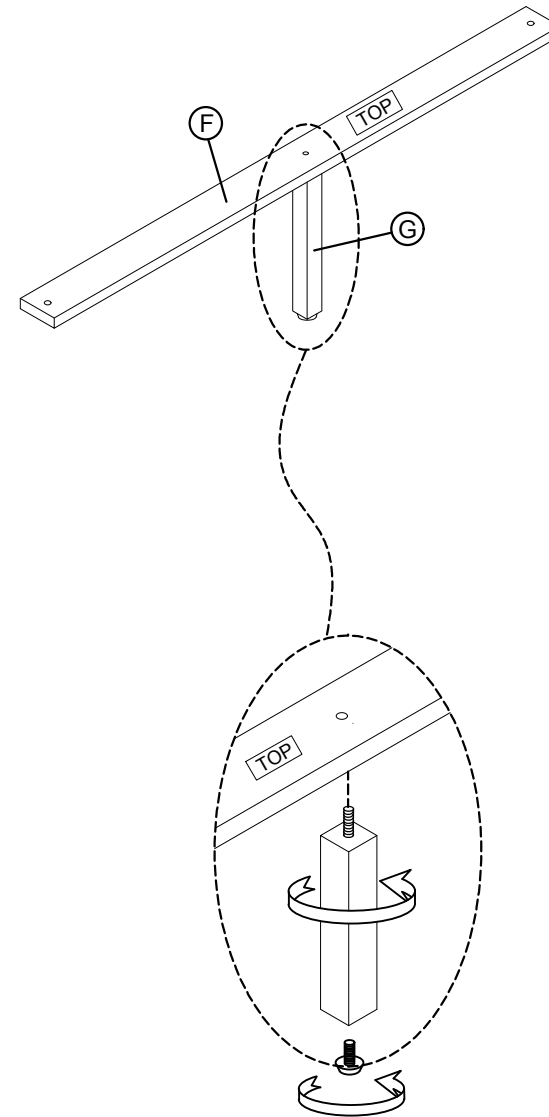

"THE HARDWARE IS LOCATED IN THE PACKING ITEMS"

NOTE: Periodically check to ensure that all connectors (bolts, screws, etc.) are tight.

NOTA: Verifique periódicamente que todos los conectores (tuercas, tornillos, etc.) estén bien apretados.

STEP 5

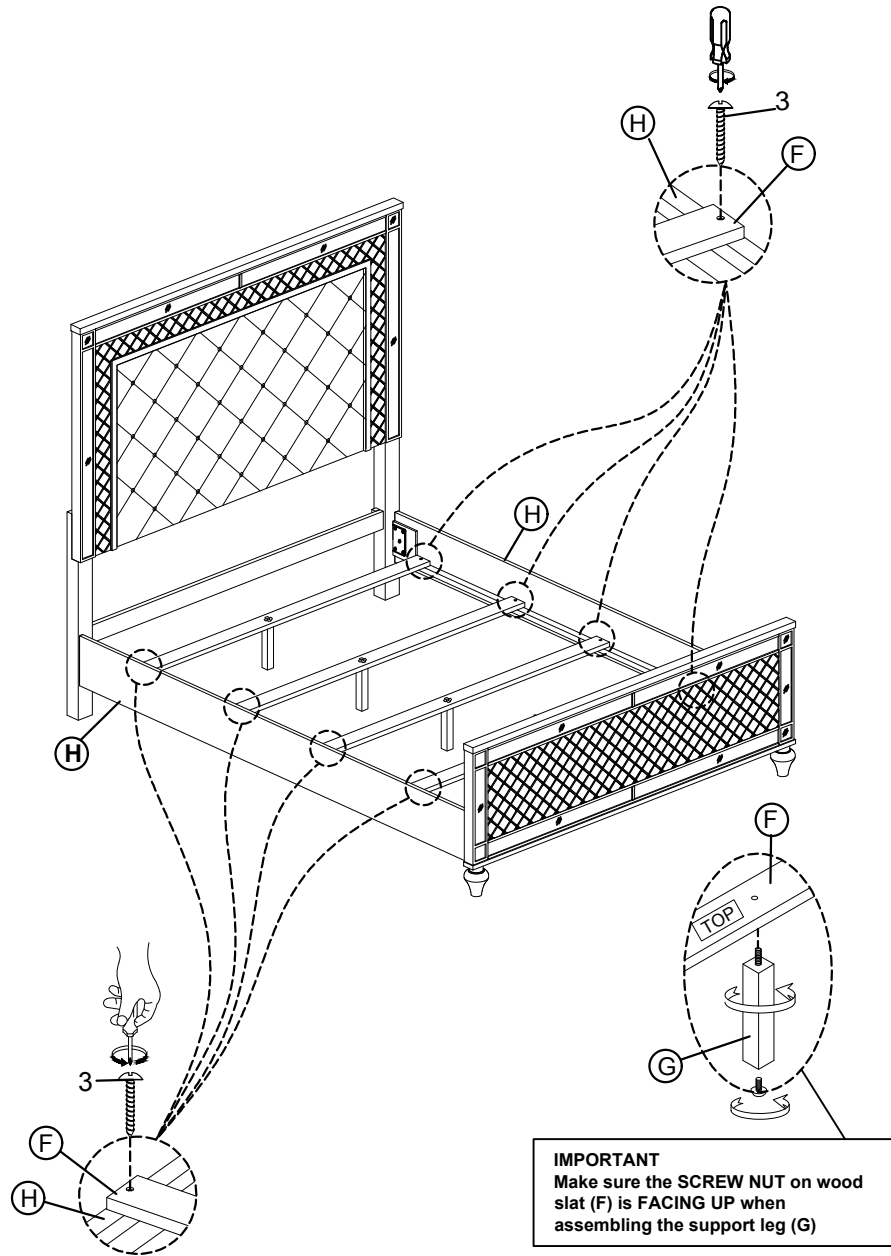

IMPORTANT
Make sure the **SCREW NUT** on wood slat (F) is **FACING UP** when assembling the support leg (G)

"THE HARDWARE IS LOCATED IN THE PACKING ITEMS"

STEP 6
COMPLETED

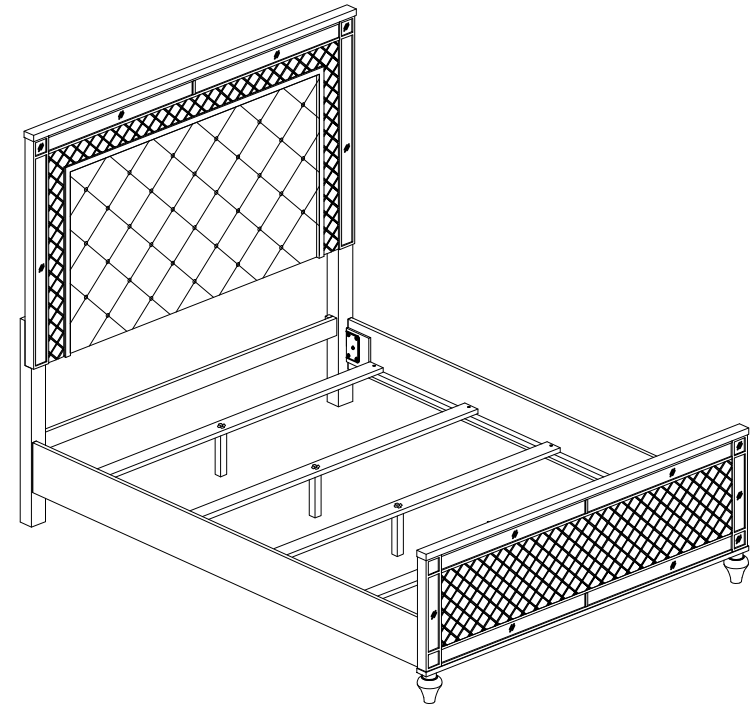

NOTE: Periodically check to ensure that all connectors (bolts, screws, etc.) are tight.

NOTA: Verifique periódicamente que todos los conectores (tuercas, tornillos, etc.) estén bien apretados.