

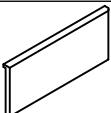





# ASSEMBLY INSTRUCTION INSTRUCCIONES

# B1750-Q-HBFB/ B1750-KQ-RAIL QUEEN BED







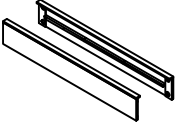

## (BOX 1) BOX OF HEADBOARD AND FOOTBOARD

Code	Parts	Qty
A	Headboard 	1pc/ PIEZA
B	Headboard Leg(L&R) 	2pcs/ PIEZA
C	Headboard Stretcher 	1pc/ PIEZA
D	Footboard 	1pc/ PIEZA
E	Slat 	4pcs/ PIEZA
F	Support Leg 	4pcs/ PIEZA

## (BOX 2) BOX OF SIDE RAIL

Code	Parts	Qty
G	Side Rail 	2pcs/ PIEZA

## (BOX 1) HARDWARE LIST

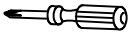
Code	Hardware	Qty
1	Bolt  Ø1/4"-20 x 1-1/2"L	8pcs/ PIEZAS
2	Theaded rod Ø5/16"-18 x 3-1/2"L 	8pcs/ PIEZAS
3	Spring washer half moon 5/16" 	8pcs/ PIEZAS
4	Spring washer 5/16" 	8pcs/ PIEZA
5	Hexnut 5/16" 	8pcs/ PIEZAS
6	Wrench 5/16" 	1pc/ PIEZAS
7	Allen wrench 1/4" 	1pc/ PIEZAS
8	Wood Screw #4x30mm 	8pcs/ PIEZAS
ASSEMBLY TOOL NOT INCLUDED 		

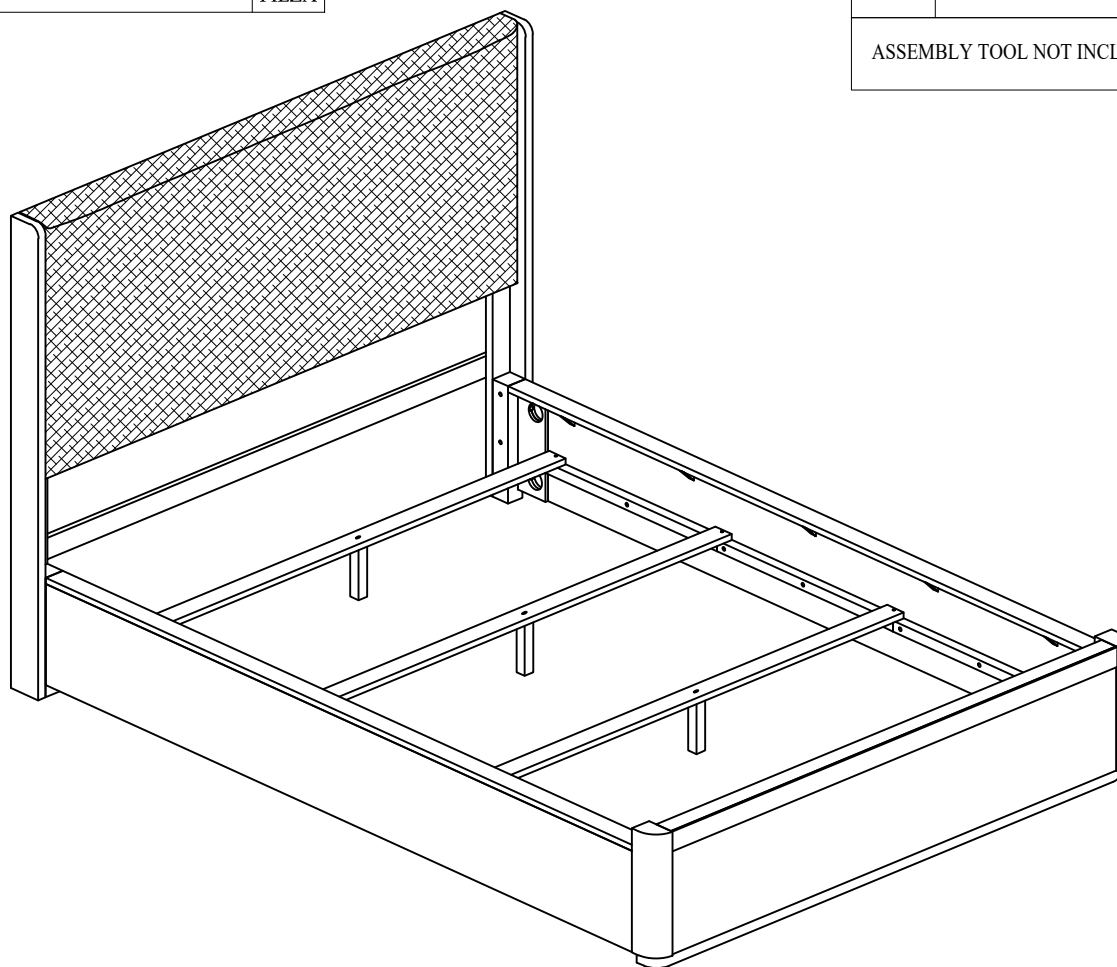

**NOTE : DURING ASSEMBLY, DO NOT FULLY TIGHTEN ANY  
HARDWARE UNTIL THE COMPLETE  
UNIT HAS BEEN ASSEMBLED.**

**THE HARDWARE IS LOCATED IN THE PACKING ITEMS**

NOTE: Periodically check to ensure that all connectors (bolts, screws, etc.) are tight.  
NOTA: Verifique periódicamente que todos los conectores (tuercas, tornillos, etc.) estén bien apretados.

STEP 1

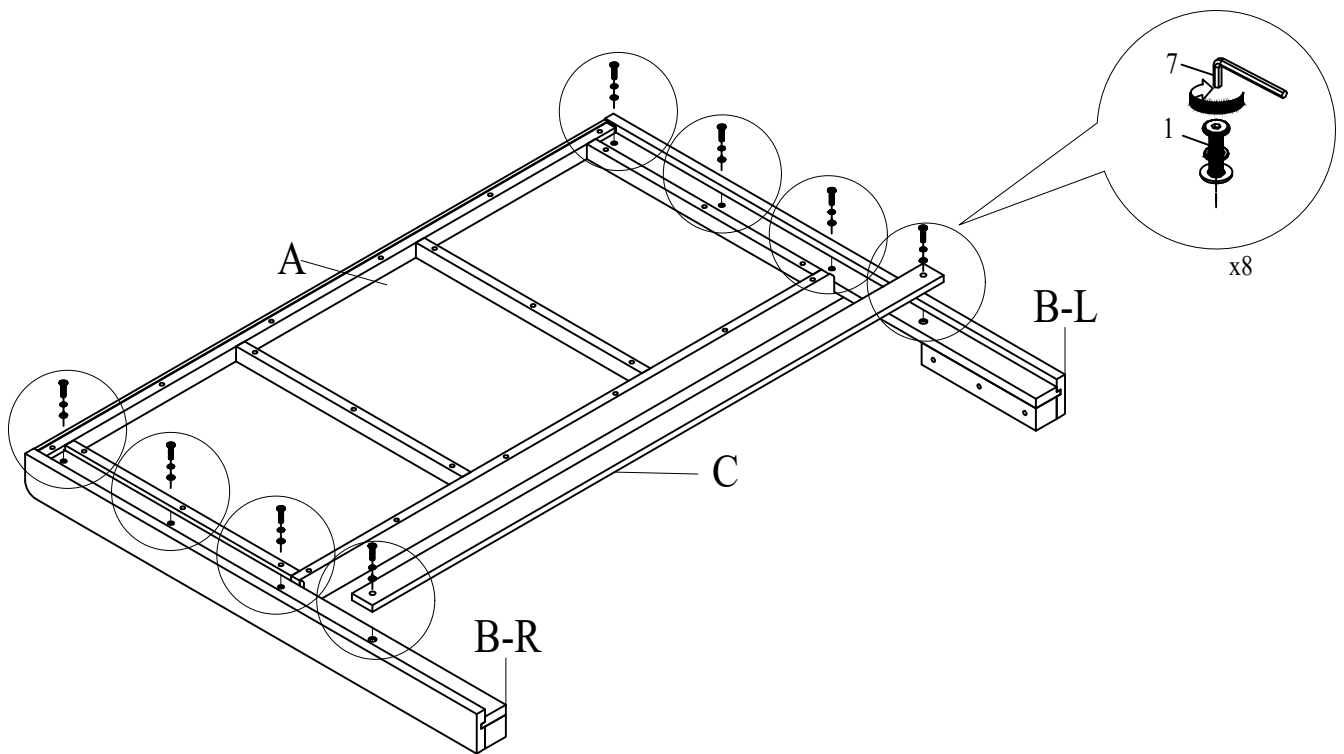

STEP 2

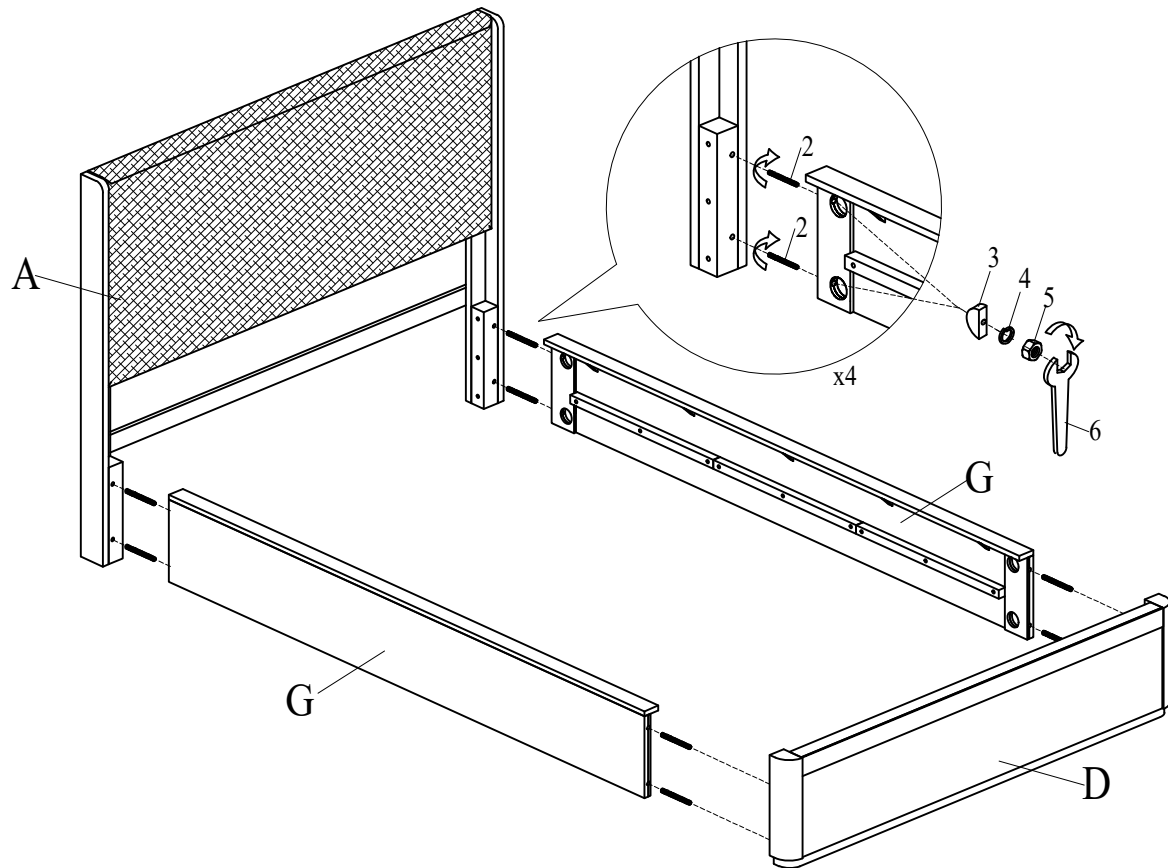

THE HARDWARE IS LOCATED IN THE PACKING ITEMS

NOTE: Periodically check to ensure that all connectors (bolts, screws, etc.) are tight.  
NOTA: Verifique periódicamente que todos los conectores (tuercas, tornillos, etc.) estén bien apretados.

STEP 3

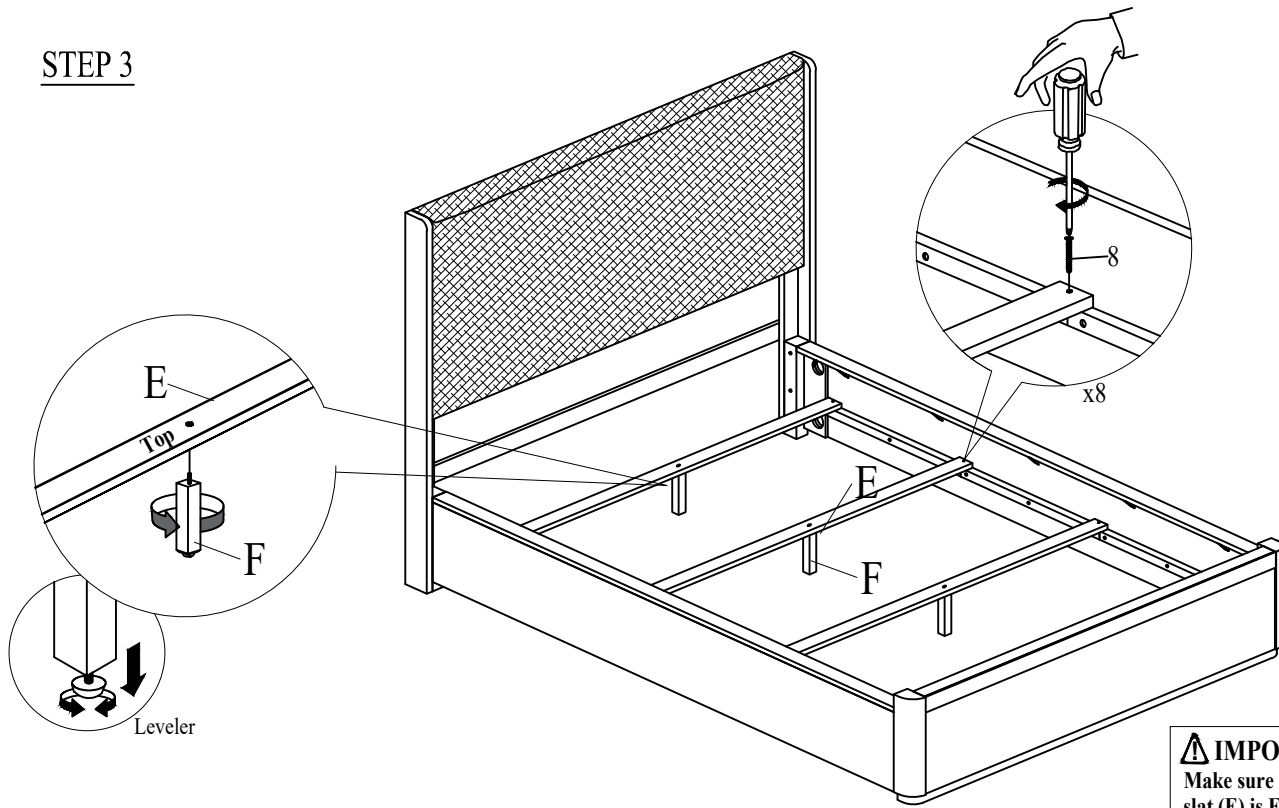

**⚠ IMPORTANT**  
Make sure the SCREW NUT on wood slat (E) is FACING UP when assembling the support leg (F)

ASSEMBLY COMPLETED

