

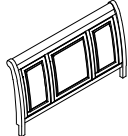







ASSEMBLY INSTRUCTION INSTRUCCIONES

B1810-Q-HB/ B1810-Q-FBD/ B1810-KQ-RAIL B1820-Q-HB/ B1820-Q-FBD/ B1820-KQ-RAIL QUEEN BED

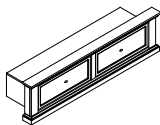
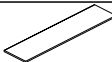
(BOX 1)
BOX OF HEADBOARD

Code	Parts	Qty
A	Headboard 	1pc/ PIEZA
B	Headboard Leg (L&R) 	2pcs/ PIEZAS
C	Headboard Stretcher 	1pc/ PIEZA



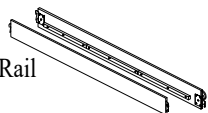

(BOX 2)
BOX OF FOOTBOARD

Code	Parts	Qty
D	Footboard 	1pc/ PIEZA
E	Decking 	5pcs/ PIEZAS
F	Slat 	2pcs/ PIEZAS
G	Middle Slat 	2pcs/ PIEZAS
H	Long Support Leg 	4pcs/ PIEZAS
I	Bun Foot 	2pcs/ PIEZAS
J	Short Support Leg 	2pcs/ PIEZAS

(BOX 3)
BOX OF SIDE RAIL

Code	Parts	Qty
K	Side Rail 	2pcs/ PIEZAS

(BOX 1)
HARDWARE LIST

Code	Hardware	Qty
1	Wood Dowel Ø8x30 mm 	4pcs/ PIEZAS
2	Bolt Ø5/16"-18 x 1-3/4"L 	6pcs/ PIEZAS
3	Allen Wrench K4 	1pc/ PIEZA
4	#4x30mm Wood Screw 	8pcs/ PIEZAS
5	#4x20mm Wood Screw 	10pcs/ PIEZAS

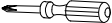
ASSEMBLY TOOL NOT INCLUDED 

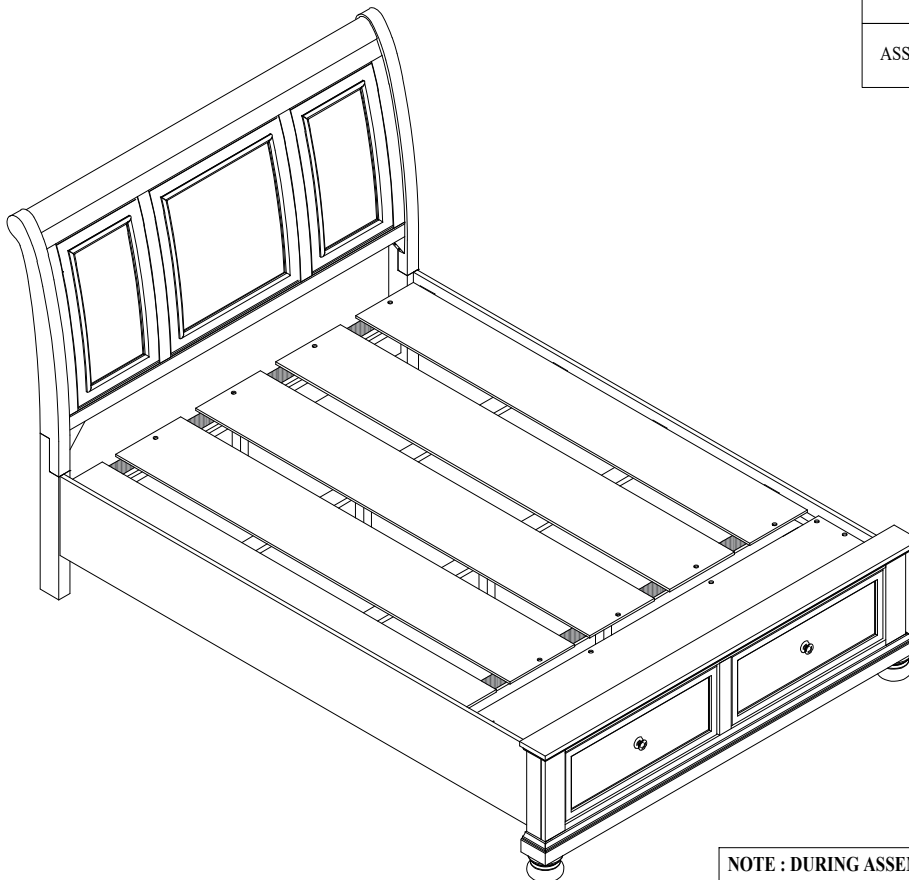

NOTE : DURING ASSEMBLY, DO NOT FULLY TIGHTEN ANY
HARDWARE UNTIL THE COMPLETE
UNIT HAS BEEN ASSEMBLED.

THE HARDWARE IS LOCATED IN THE PACKING ITEMS

NOTE: Periodically check to ensure that all connectors (bolts, screws, etc.) are tight.
NOTA: Verifique periódicamente que todos los conectores (tuercas, tornillos, etc.) estén bien apretados.

ASSEMBLY INSTRUCTION
INSTRUCCIONES

B1810-Q-HB/ B1810-Q-FBD/ B1810-KQ-RAIL
B1820-Q-HB/ B1820-Q-FBD/ B1820-KQ-RAIL
QUEEN BED

STEP 1

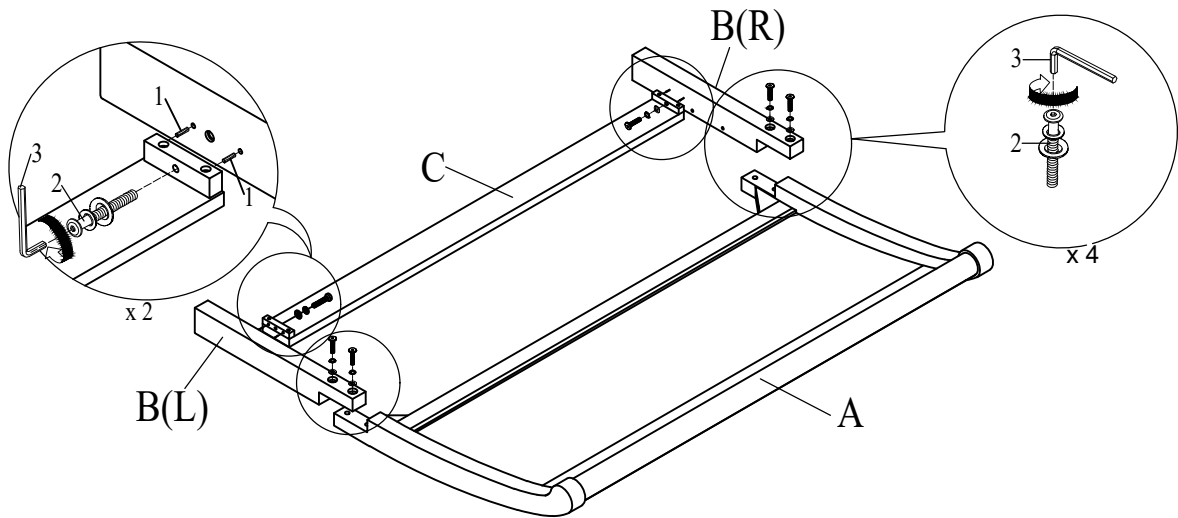

STEP 2

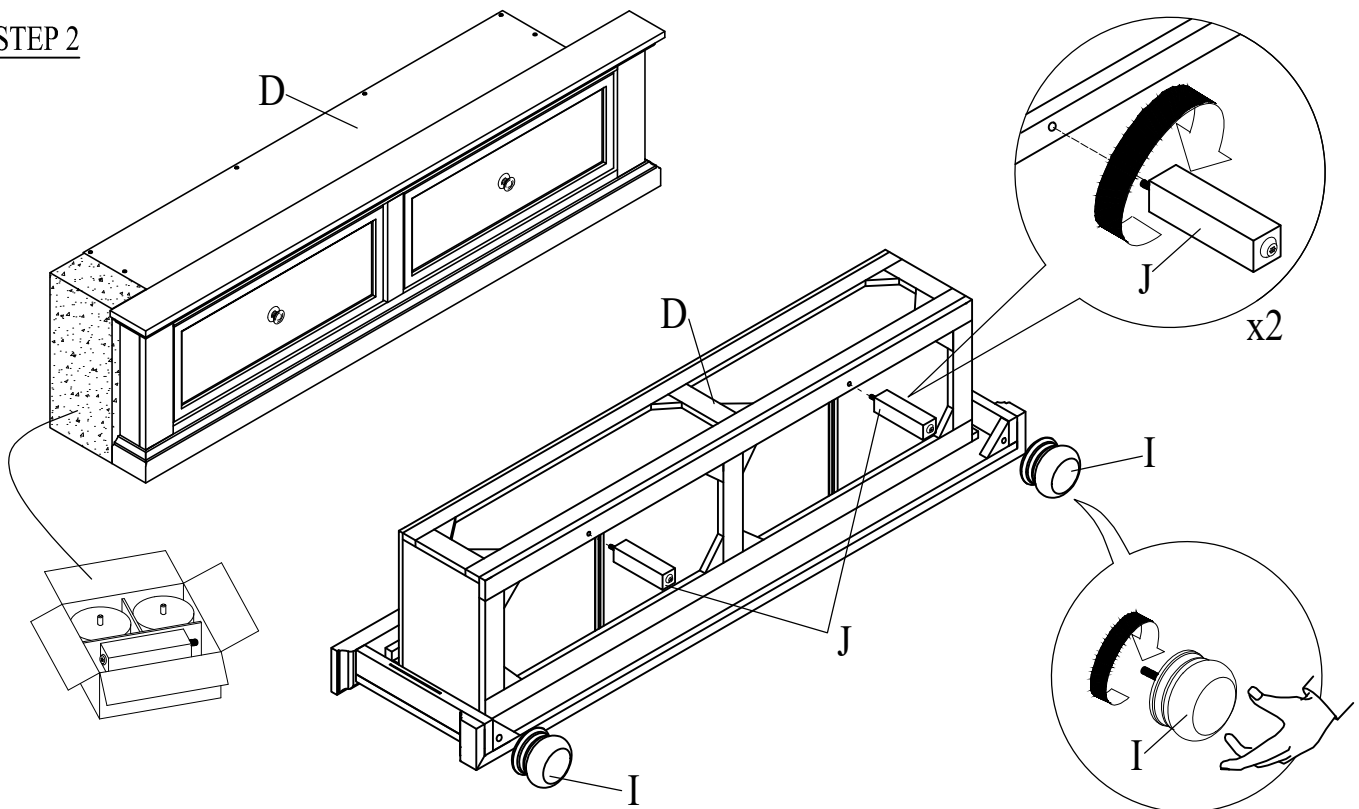

THE HARDWARE IS LOCATED IN THE PACKING ITEMS

NOTE: Periodically check to ensure that all connectors (bolts, screws, etc.) are tight.
NOTA: Verifique periódicamente que todos los conectores (tuercas, tornillos, etc.) estén bien apretados.

**ASSEMBLY INSTRUCTION
INSTRUCCIONES**

**B1810-Q-HB/ B1810-Q-FBD/ B1810-KQ-RAIL
B1820-Q-HB/ B1820-Q-FBD/ B1820-KQ-RAIL
QUEEN BED**

STEP 3

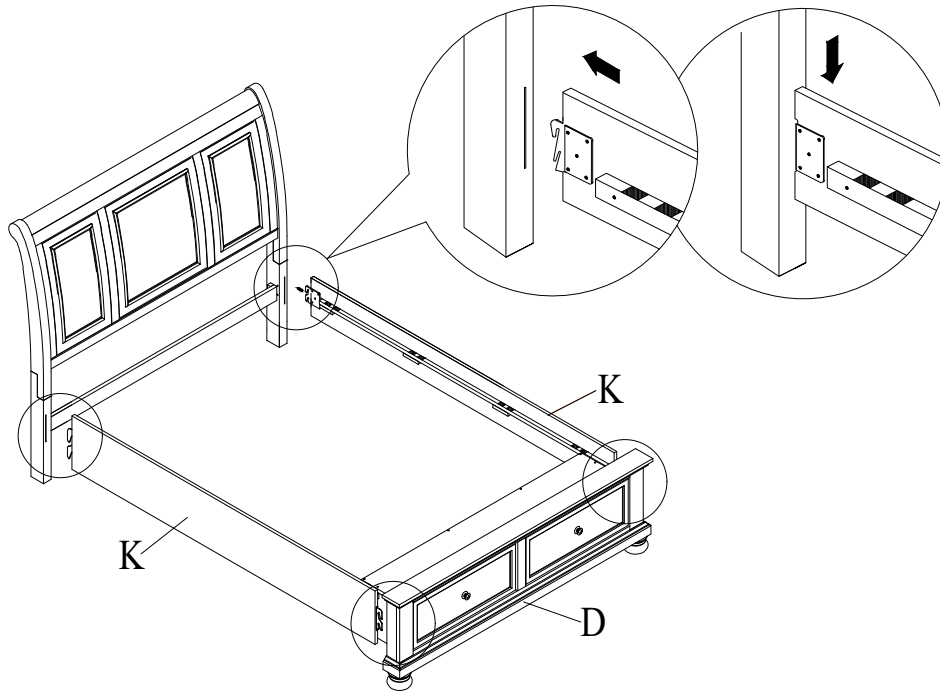

STEP 4

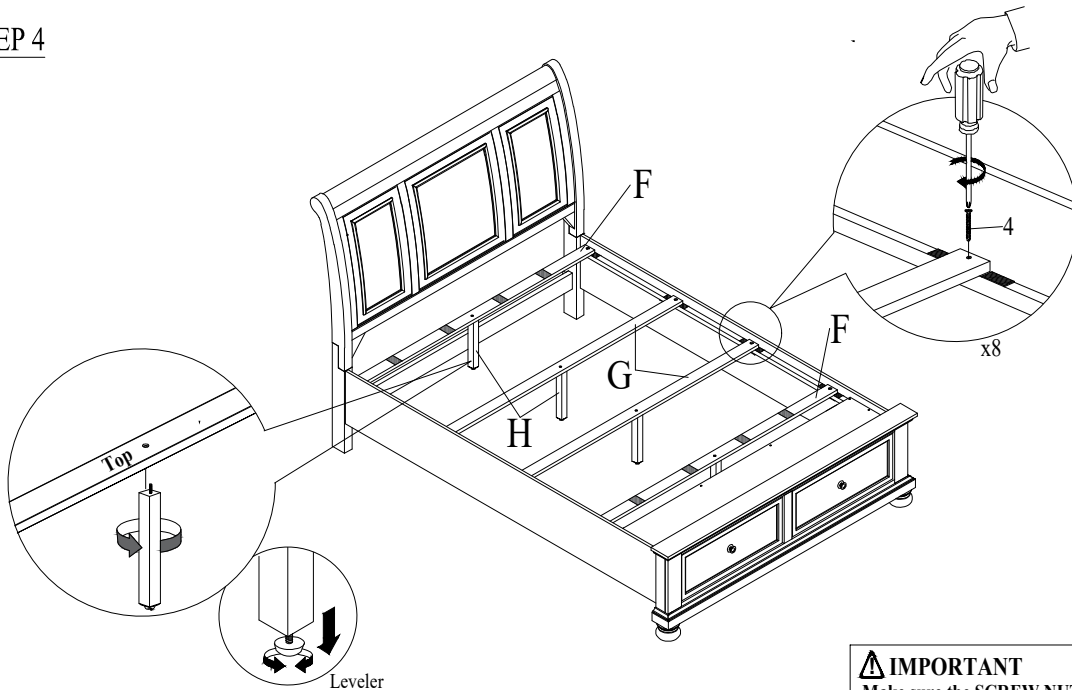

⚠ IMPORTANT
Make sure the **SCREW NUT** on wood slat (F-G) is **FACING UP** when assembling the Long support leg (H)

THE HARDWARE IS LOCATED IN THE PACKING ITEMS

NOTE: Periodically check to ensure that all connectors (bolts, screws, etc.) are tight.
NOTA: Verifique periódicamente que todos los conectores (tuercas, tornillos, etc.) estén bien apretados.

**ASSEMBLY INSTRUCTION
INSTRUCCIONES**

**B1810-Q-HB/ B1810-Q-FBD/ B1810-KQ-RAIL
B1820-Q-HB/ B1820-Q-FBD/ B1820-KQ-RAIL
QUEEN BED**

STEP 5

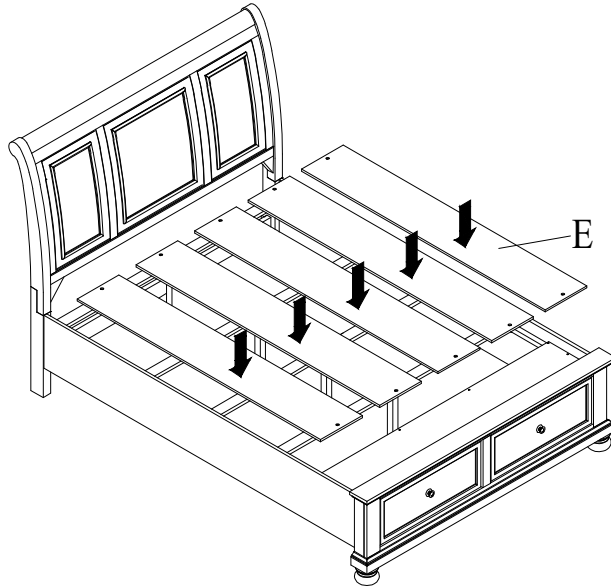

ASSEMBLY COMPLETED

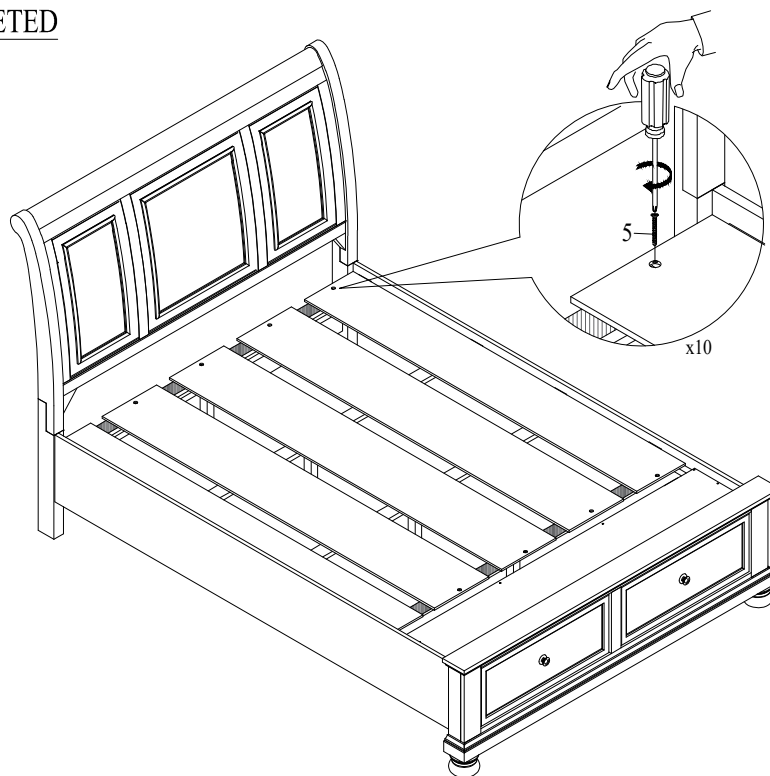

THE HARDWARE IS LOCATED IN THE PACKING ITEMS

NOTE: Periodically check to ensure that all connectors (bolts, screws, etc.) are tight.
NOTA: Verifique periódicamente que todos los conectores (tuercas, tornillos, etc.) estén bien apretados.