



ASSEMBLY INSTRUCTION INSTRUCCIONES



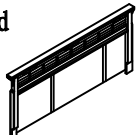
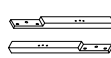

B1900-Q-HB/ B1900-Q-FB/ B1900-KQ-RAIL B1950-Q-HB/ B1950-Q-FB/ B1950-KQ-RAIL QUEEN BED

(BOX 1) BOX OF HEADBOARD

(BOX 2) BOX OF FOOTBOARD

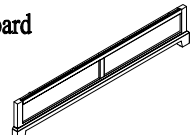

(BOX 3) BOX OF SIDE RAIL

Code	Parts	Qty
A	Headboard 	1pc/ PIEZA
B	Headboard Leg (L&R) 	2pcs/ PIEZAS
C	Headboard Stretcher 	1pc/ PIEZA





Code	Parts	Qty
D	Footboard 	1pc/ PIEZA
E	Footboard frame with cushion 	1pc/ PIEZA
F	DECORATIVE IRON 	3pcs/ PIEZAS
G	Slat 	4pcs/ PIEZAS
H	Support Leg 	4 pcs/ PIEZAS

Code	Parts	Qty
I	Side Rail 	2pcs/ PIEZAS

(BOX 1) HARDWARE LIST

Code	Hardware	Qty
1	BOLT Ø5/16" - 18 x 1-3/4"L 	8pcs/ PIEZAS
2	1/4" ALLEN WRENCH 	1pc/ PIEZA

(BOX 2) HARDWARE LIST

Code	Hardware	Qty
3	BOLT Ø1/4" - 20 x 1-1/2"L 	8pcs/ PIEZAS
4	BOLT Ø1/4" - 20 x 3/4"L 	6pcs/ PIEZAS
5	Ø1/4" Allen Wrench 	1pc/ PIEZA
6	#8x30mm WOODSCREW 	8pcs/ PIEZAS

ASSEMBLY TOOL NOT INCLUDED 

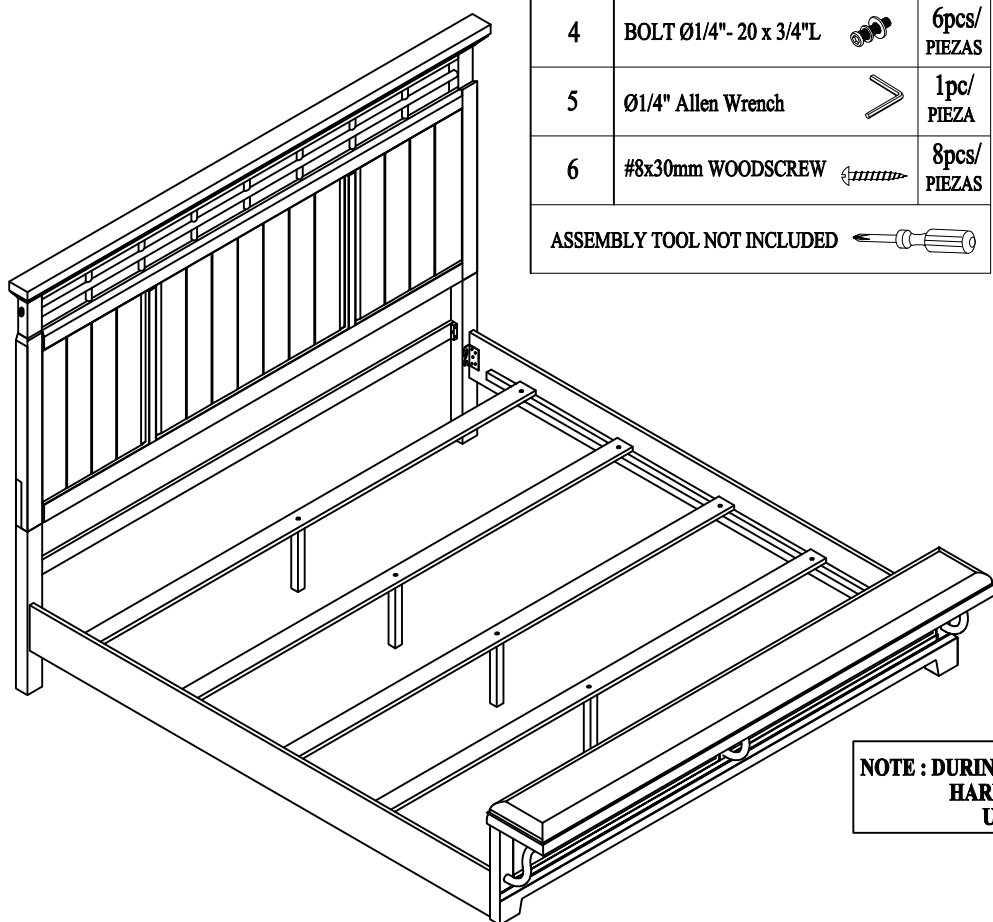

**NOTE : DURING ASSEMBLY, DO NOT FULLY TIGHTEN ANY
HARDWARE UNTIL THE COMPLETE
UNIT HAS BEEN ASSEMBLED.**

THE HARDWARE IS LOCATED IN THE PACKING ITEMS

NOTE: Periodically check to ensure that all connectors (bolts, screws, etc.) are tight.
NOTA: Verifique periódicamente que todos los conectores (tuercas, tornillos, etc.) estén bien apretados.

ASSEMBLY INSTRUCTION
INSTRUCCIONES

B1900-Q-HB/ B1900-Q-FB/ B1900-KQ-RAIL
B1950-Q-HB/ B1950-Q-FB/ B1950-KQ-RAIL
QUEEN BED

STEP 1

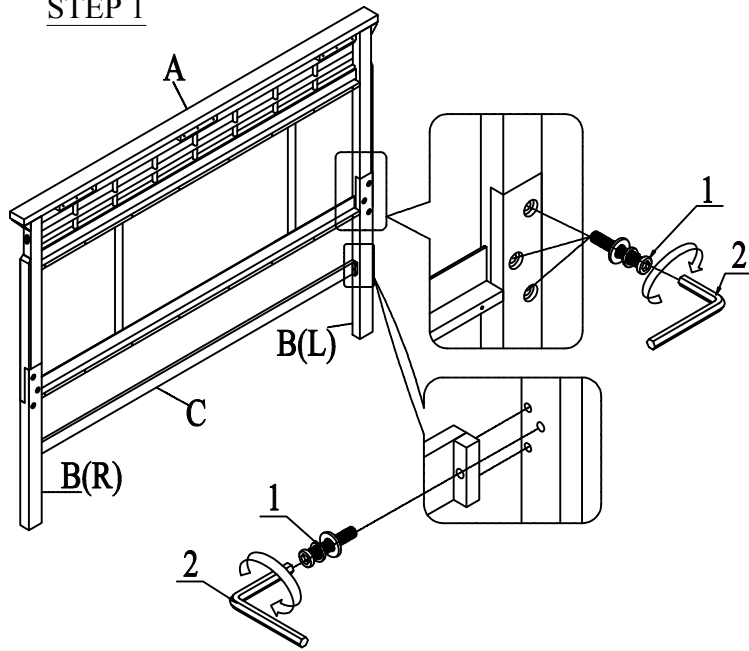

STEP 2

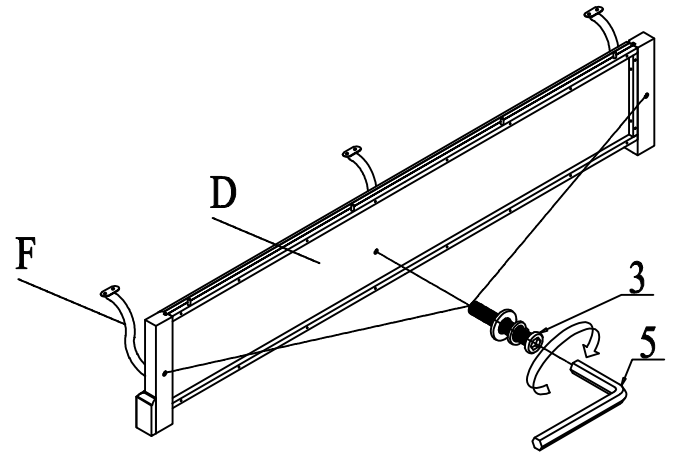

STEP 3

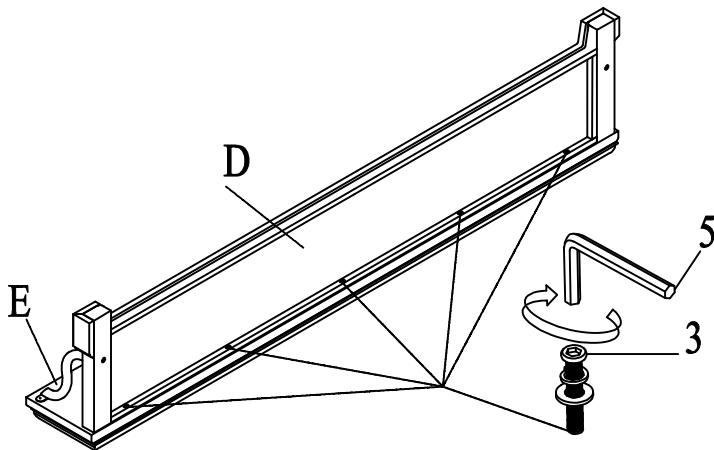

STEP 4

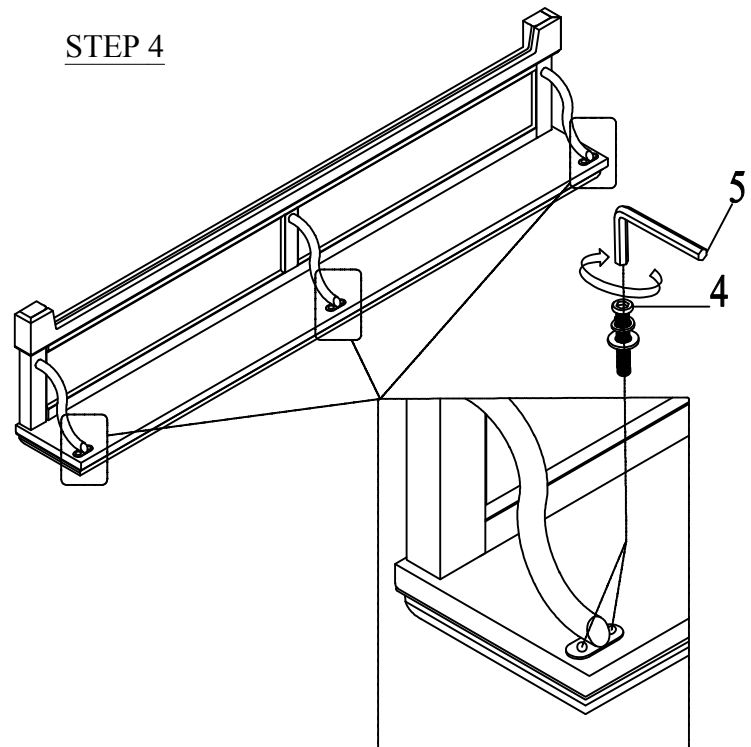

THE HARDWARE IS LOCATED IN THE PACKING ITEMS

NOTE: Periodically check to ensure that all connectors (bolts, screws, etc.) are tight.
NOTA: Verifique periódicamente que todos los conectores (tuercas, tornillos, etc.) estén bien apretados.

ASSEMBLY INSTRUCTION INSTRUCCIONES

B1900-Q-HB/ B1900-Q-FB/ B1900-KQ-RAIL B1950-Q-HB/ B1950-Q-FB/ B1950-KQ-RAIL QUEEN BED

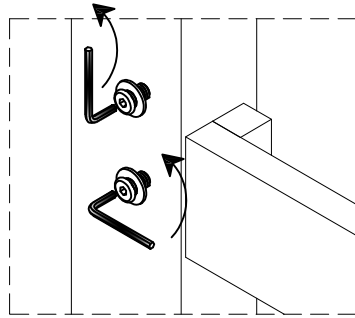

Loose all the bolts

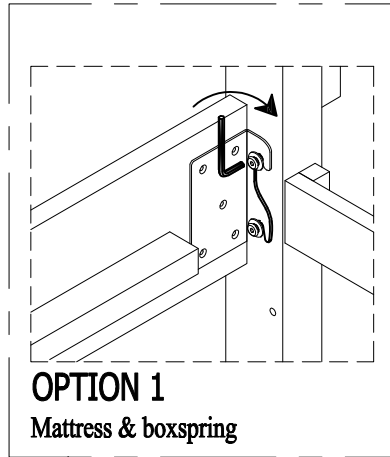

OPTION 1

Mattress & boxspring

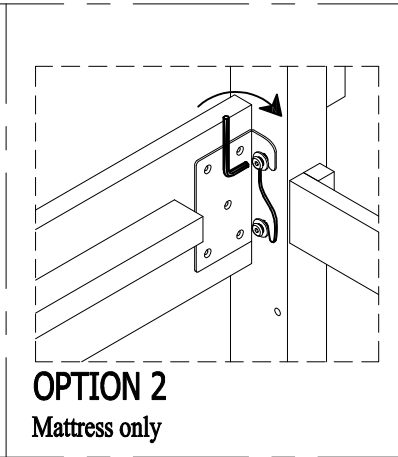

OPTION 2

Mattress only

STEP 5

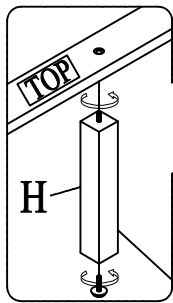
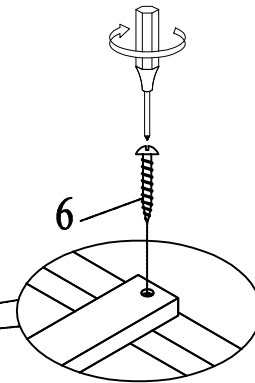
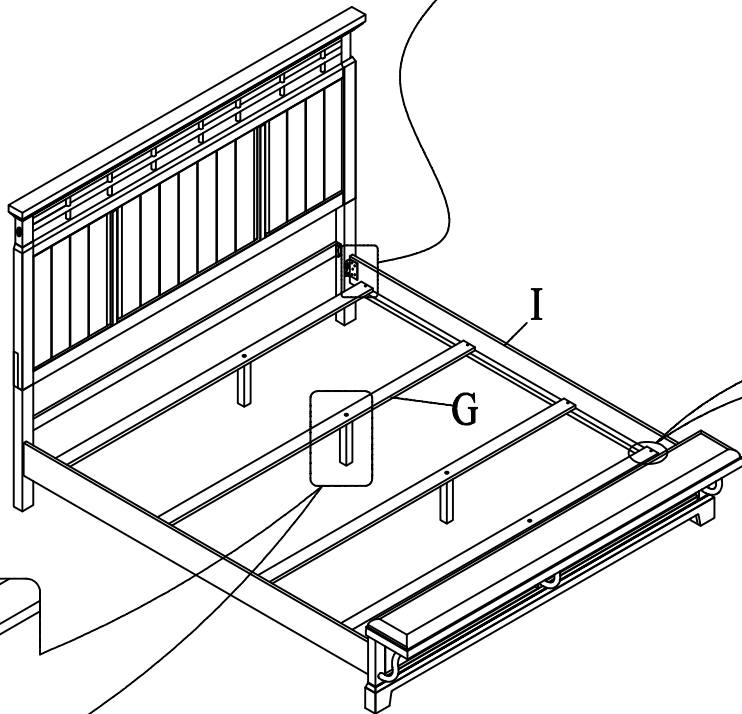

IMPORTANT
Make sure the SCREW NUT on wood slat (G) is FACING UP when assembling the support leg (H)

COMPLETE

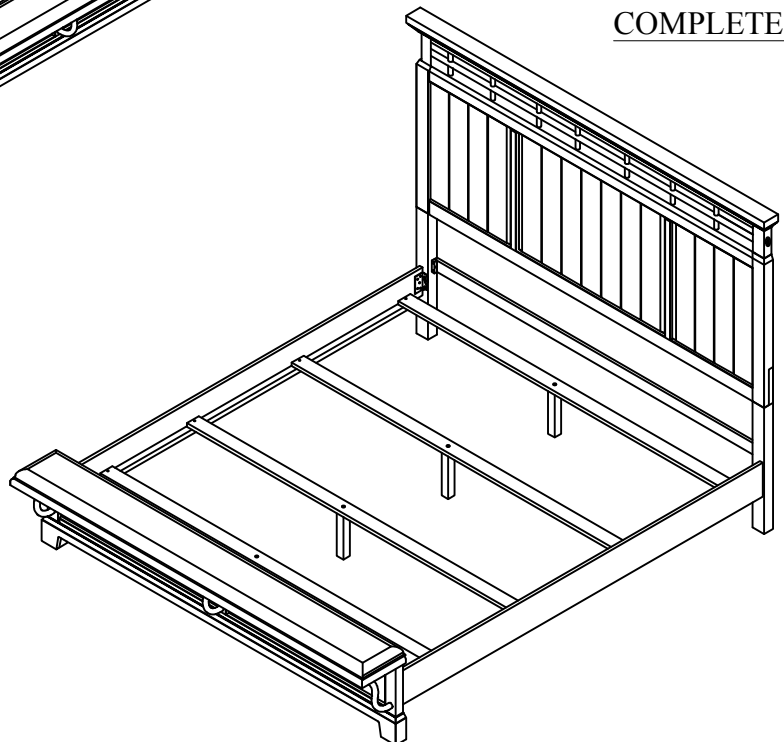

THE HARDWARE IS LOCATED IN THE PACKING ITEMS

NOTE: Periodically check to ensure that all connectors (bolts, screws, etc.) are tight.
NOTA: Verifique periódicamente que todos los conectores (tuercas, tornillos, etc.) estén bien apretados.