







ASSEMBLY INSTRUCTIONS

ITEM NO : B2180-K-HB / B2180-KQ-HBLEG
ITEM NO : B2180-Q-HB / B2180-KQ-HBLEG

**(BOX 1)
BOX OF HEADBOARD**

ITEM	DRAWING	DESCRIPTION	QTY
A		HEADBOARD	1
B		HEADBOARD INNER LEG SUPPORT	2
C		HEADBOARD LEG SUPPORT	2

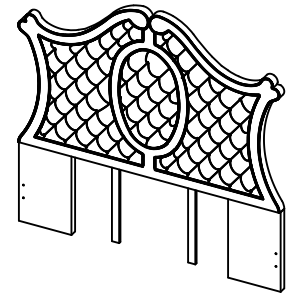

**(BOX 1)
HARDWARE LIST**

ITEM	DRAWING	DESCRIPTION	QTY
1		SHORT ALLEN KEY (M4)	1
2		CONNECTION BOLT (M6 x 40mm) W/SPRING WASHER & WASHER MEDIUM	4
3		CONNECTION BOLT (M6 x 40mm) W/SPRING WASHER, WASHER MEDIUM, & WASHER LARGE	12



**COMPLETED HEADBOARD
ASSEMBLY**

**(BOX 2)
BOX OF HEADBOARD LEG**

ITEM	DRAWING	DESCRIPTION	QTY
D		HEADBOARD LEG - RIGHT	1
E		HEADBOARD LEG - LEFT	1

STEP 1

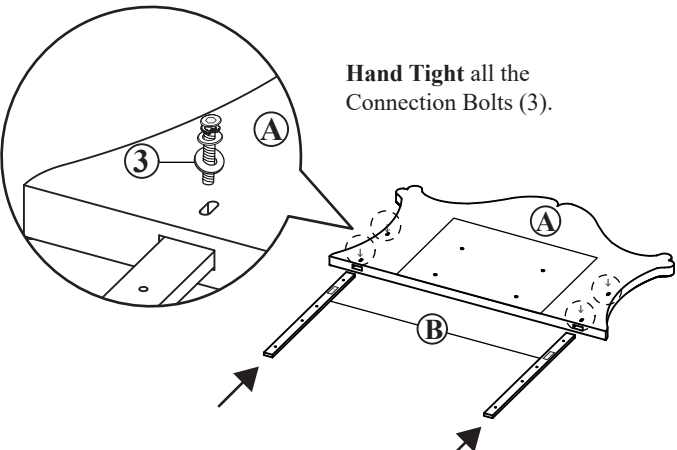

Hand Tight all the Connection Bolts (3).

STEP 2

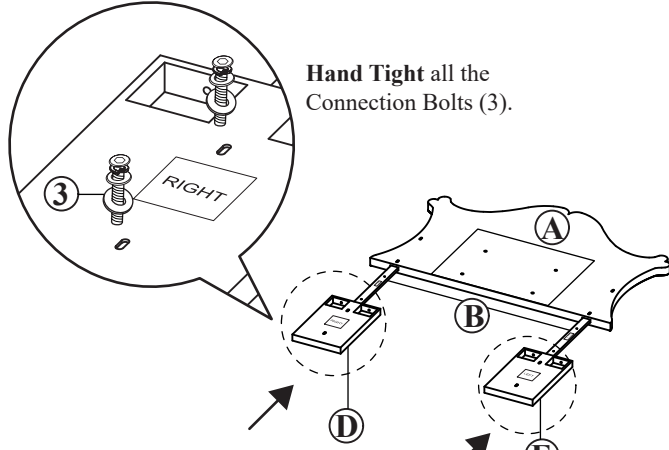

Hand Tight all the Connection Bolts (3).

STEP 3

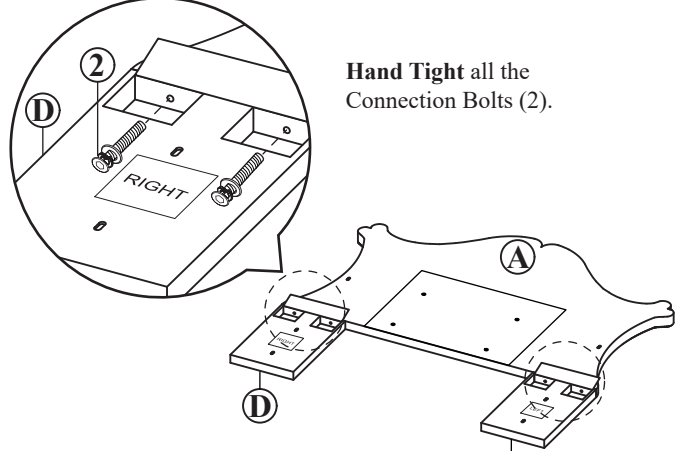

Hand Tight all the Connection Bolts (2).

STEP 4

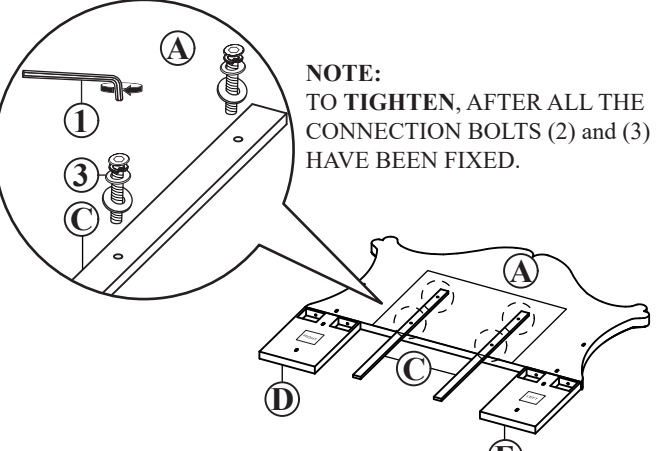

NOTE:
TO TIGHTEN, AFTER ALL THE CONNECTION BOLTS (2) and (3) HAVE BEEN FIXED.

THE HARDWARE IS LOCATED IN THE PACKING ITEMS.

NOTE : MUST TIGHTEN THE BOLTS & SCREWS PERIODICALLY. WITH USE BOLTS & SCREWS MAY BECOME LOOSE. CHECK TIGHTNESS OF ALL BOLTS & SCREWS EVERY 6-8 WEEKS.

CLEANING INSTRUCTION





After assembly, clean & polish the completed parts if necessary with soft cloth and industrial recognized furniture polish

MADE IN MALAYSIA

ASSEMBLY INSTRUCTIONS

ITEM NO : B2180-K-FB / B2180-KQ-RAIL
KING BED







**(BOX 1)
BOX OF FOOTBOARD**

ITEM	DRAWING	DESCRIPTION	QTY
A		FOOTBOARD	1
B		BUN FOOT	2
C		WOODEN SLAT	4
D		WOODEN SUPPORT WITH ADJUSTER	8

**(BOX 2)
BOX OF SIDE RAIL**

ITEM	DRAWING	DESCRIPTION	QTY
E		SIDE RAIL	2

**(BOX 1)
HARDWARE LIST**

ITEM	DRAWING	DESCRIPTION	QTY
1		ALLEN KEY (M4)	1
2		ALLEN KEY (M5)	1
3		CONNECTION BOLT (M8 x 30mm) W/SPRING WASHER & WASHER MEDIUM	8
4		CONNECTION BOLT (M6 x 40mm)	8
5		CSK SCREW (M4 x 32mm)	8
6		SCREW DRIVER (*)	1

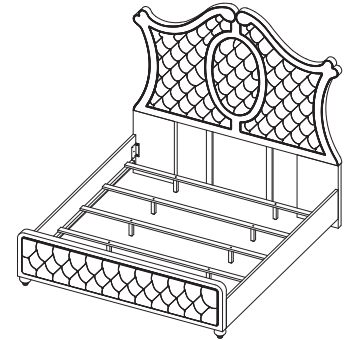

**COMPLETED KING BED
ASSEMBLY**

(*) The Manufacturer does not provide item 6.

STEP 1

Please refer ITEM NO : B2100-K-HB / B2100-KQ-HBLEG
ITEM NO : B2100-Q-HB / B2100-KQ-HBLEG

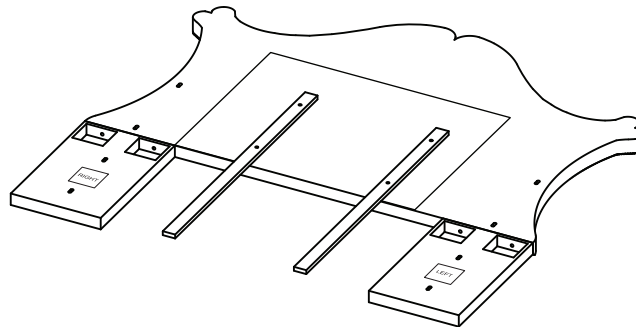

STEP 2

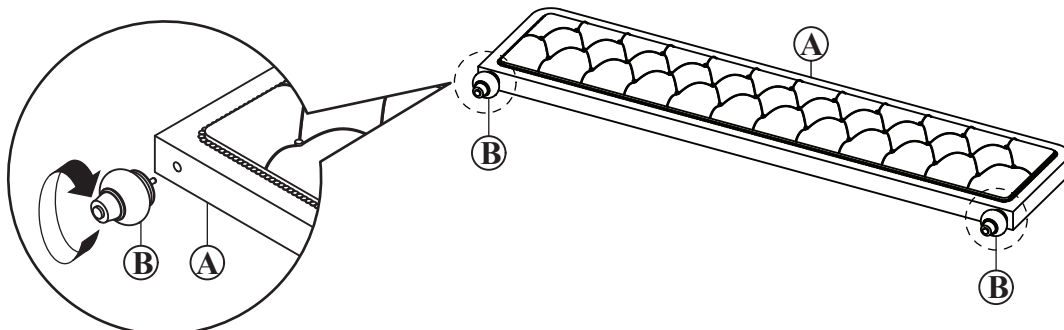

THE HARDWARE IS LOCATED IN THE PACKING ITEMS.

NOTE : MUST TIGHTEN BOLTS & SCREWS PERIODICALLY. WITH USE BOLTS & SCREWS MAY BECOME LOOSE.
CHECK TIGHTNESS OF ALL BOLTS & SCREWS EVERY 6-8 WEEKS.

CLEANING INSTRUCTION

After assembly, clean & polish the completed parts if necessary with soft cloth and industrial recognized furniture polish

MADE IN MALAYSIA

ASSEMBLY INSTRUCTIONS

ITEM NO : B2180-K-FB / B2180-KQ-RAIL
KING BED

STEP 3

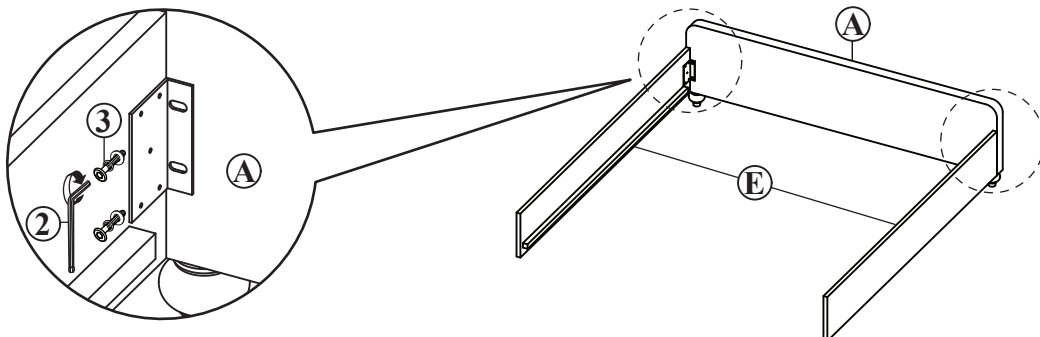

STEP 4

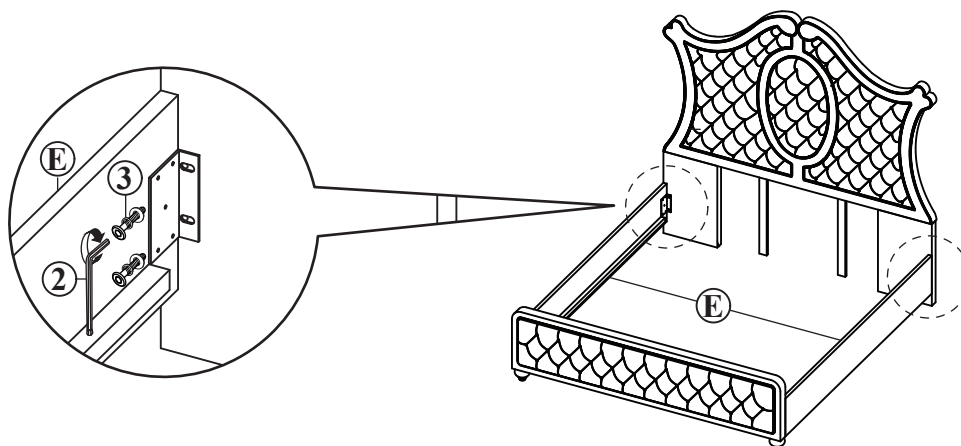

STEP 5

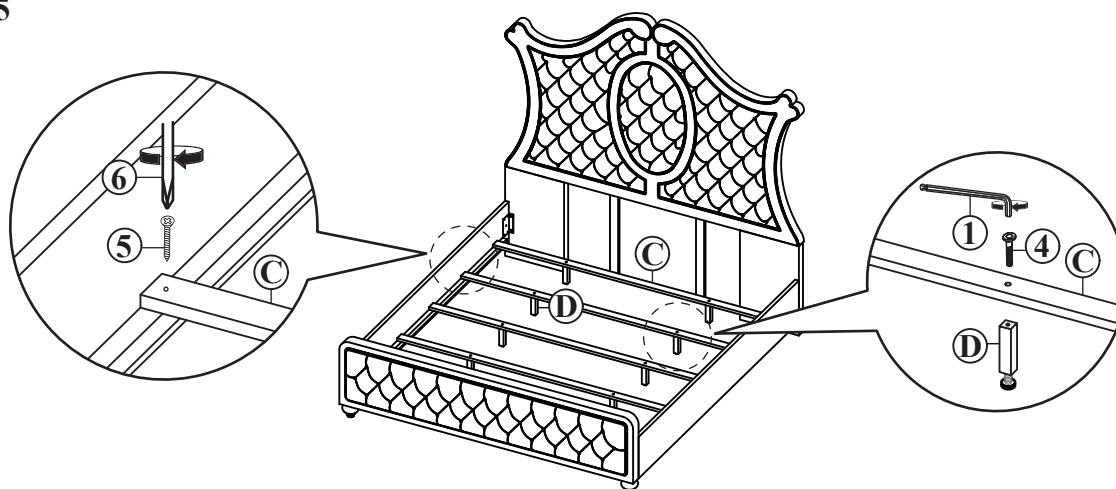

THE HARDWARE IS LOCATED IN THE PACKING ITEMS.

NOTE : MUST TIGHTEN BOLTS & SCREWS PERIODICALLY. WITH USE BOLTS & SCREWS MAY BECOME LOOSE.
CHECK TIGHTNESS OF ALL BOLTS & SCREWS EVERY 6-8 WEEKS.

CLEANING INSTRUCTION

After assembly, clean & polish the completed parts if necessary with soft cloth and industrial recognized furniture polish

MADE IN MALAYSIA