





ASSEMBLY INSTRUCTIONS

ITEM NO : B2300-Q-HB / B2300-Q-FB / B2300-KQ-HBWG
B2300-KQ-RAIL
QUEEN BED





**(BOX 1)
BOX OF HEADBOARD**

ITEM	DRAWING	DESCRIPTION	QTY
A		HEADBOARD	1
B		HEADBOARD SUPPORT	2



**(BOX 2)
BOX OF HEADBOARD WING**

ITEM	DRAWING	DESCRIPTION	QTY
C		HEADBOARD WING - LEFT	1
D		HEADBOARD WING - RIGHT	1







**(BOX 3)
BOX OF FOOTBOARD**

ITEM	DRAWING	DESCRIPTION	QTY
E		FOOTBOARD	1
F		BED LEG	2
G		WOODEN SUPPORT WITH ADJUSTER	4
H		WOODEN SLAT	4

**(BOX 4)
BOX OF SIDE RAIL**

ITEM	DRAWING	DESCRIPTION	QTY
I		SIDE RAIL - LEFT	1
J		SIDE RAIL - RIGHT	1

**(BOX 3)
BOX OF FOOTBOARD
HARDWARE LIST**

ITEM	DRAWING	DESCRIPTION	QTY
1		ALLEN KEY WITH BALL (M4)	1
2		CONNECTION BOLT (M6 x 30mm) W/SPRING WASHER & WASHER MEDIUM	4
3		CONNECTION BOLT (M6 x 40mm) W/SPRING WASHER & WASHER MEDIUM	12
4		CONNECTION BOLT (M6 x 60mm) W/SPRING WASHER & WASHER MEDIUM	6
5		JCBC BOLT (M6 x 40mm)	4
6		CSK SCREW (M4 x 32mm)	8
7		SCREW DRIVER (*)	1

(*) The Manufacturer does not provide item 7.

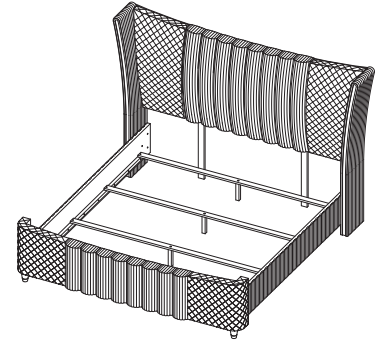

**COMPLETED QUEEN BED
ASSEMBLY**

STEP 1

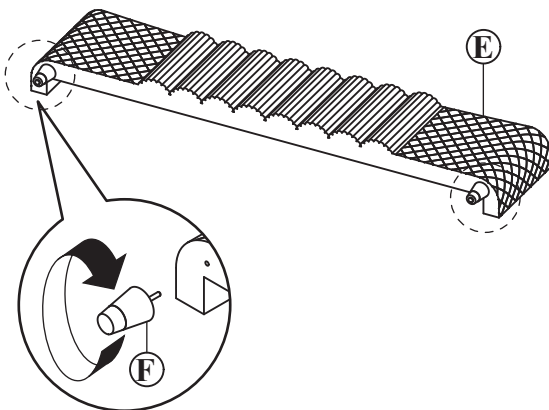

STEP 2

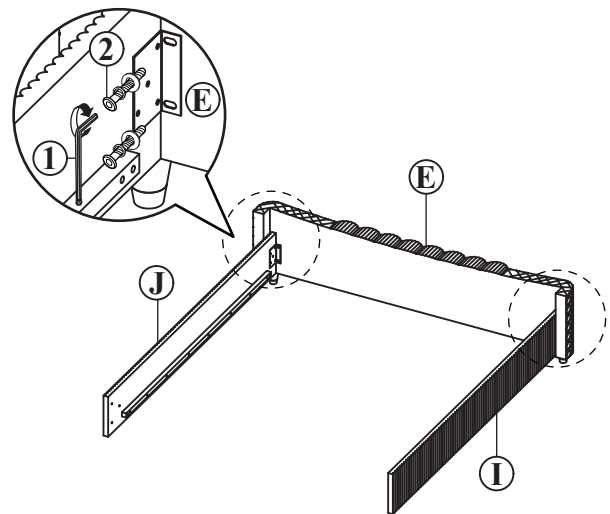

THE HARDWARE IS LOCATED IN THE PACKING ITEMS.

NOTE : PERIODICALLY CHECK TO ENSURE THAT ALL CONNECTORS (BOLTS, SCREWS, ETC.) ARE TIGHT.

CLEANING INSTRUCTION

After assembly, clean & polish the completed parts if necessary with soft cloth and industrial recognized furniture polish

MADE IN MALAYSIA

ASSEMBLY INSTRUCTIONS

ITEM NO : B2300-Q-HB / B2300-Q-FB / B2300-KQ-HBWG
B2300-KQ-RAIL
QUEEN BED

STEP 3

Hand Tighten all the Connection Bolts (3).

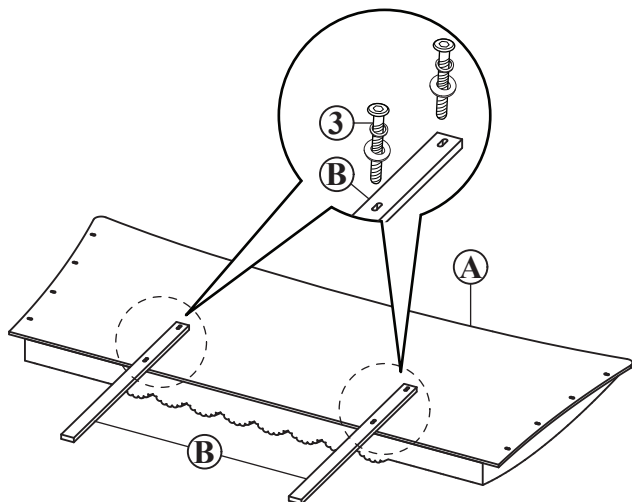

STEP 4

Hand Tighten all the Connection Bolts (3).

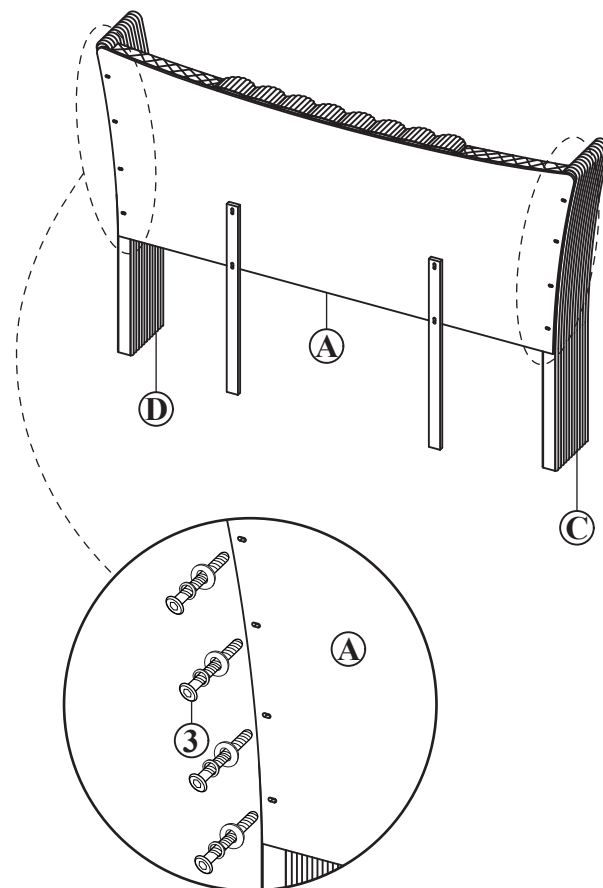

STEP 5

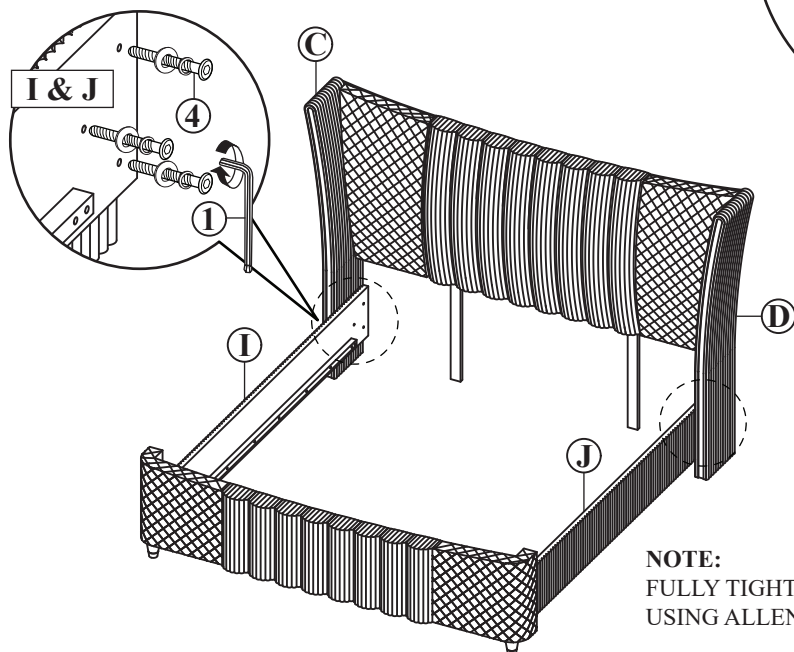

NOTE:
FULLY TIGHTEN ALL THE CONNECTION BOLTS
USING ALLEN KEY (1) AT STEP 3, 4 & 5.

THE HARDWARE IS LOCATED IN THE PACKING ITEMS.

NOTE : PERIODICALLY CHECK TO ENSURE THAT ALL CONNECTORS (BOLTS, SCREWS, ETC.) ARE TIGHT.

CLEANING INSTRUCTION

After assembly, clean & polish the completed parts if necessary with soft cloth and industrial recognized furniture polish

MADE IN MALAYSIA

ASSEMBLY INSTRUCTIONS

ITEM NO : B2300-Q-HB / B2300-Q-FB / B2300-KQ-HBWG
B2300-KQ-RAIL
QUEEN BED

STEP 6

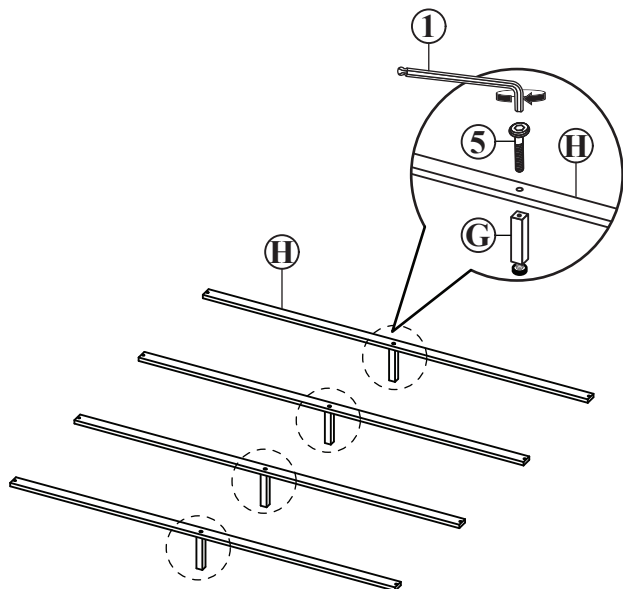

STEP 7

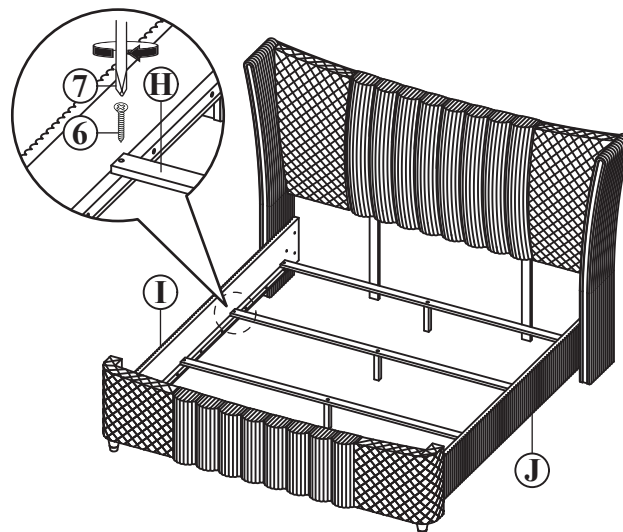

STEP 8

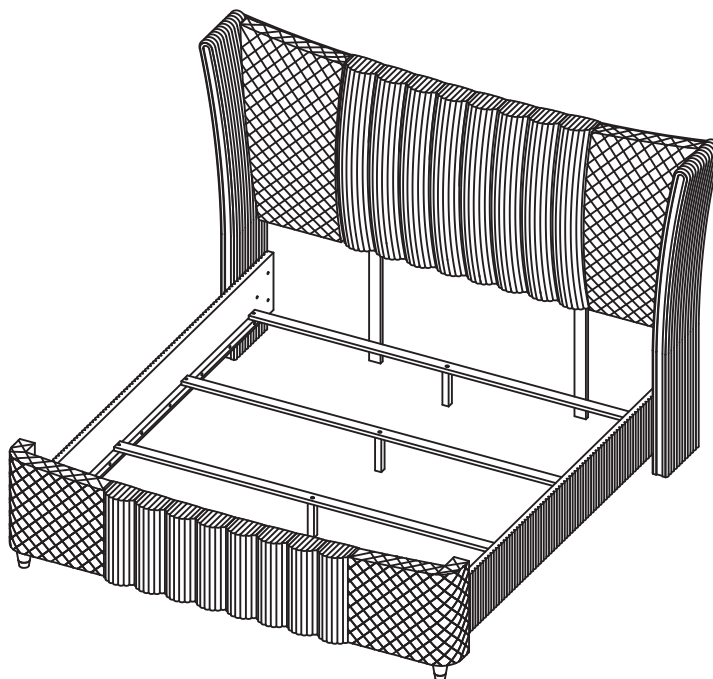

ASSEMBLY COMPLETE

THE HARDWARE IS LOCATED IN THE PACKING ITEMS.

NOTE : PERIODICALLY CHECK TO ENSURE THAT ALL CONNECTORS (BOLTS, SCREWS, ETC.) ARE TIGHT.

CLEANING INSTRUCTION

After assembly, clean & polish the completed parts if necessary with soft cloth and industrial recognized furniture polish

MADE IN MALAYSIA