











ASSEMBLY INSTRUCTIONS

ITEM NO : B3050-Q-HBFB / B3050-KQ-RAIL
QUEEN BED



BOX 1
HEADBOARD PANEL, FOOTBOARD PANEL AND HEADBOARD LEGS

ITEM	DRAWING	DESCRIPTION	QTY
A		HEADBOARD PANEL	1
B		RIGHT HEADBOARD LEG	1
C		LEFT HEADBOARD LEG	1
D		FOOTBOARD PANEL	1
E		SLAT	4
F		SLAT SUPPORT	4

BOX 1
HARDWARE LIST

ITEM	DRAWING	DESCRIPTION	QTY
1		JCBC BOLT WITH SPRING WASHER AND FLAT WASHER (M6 x 40mm)	6
2		ALLEN KEY (M4)	1
3		SCREW P/H RATTAN (8 X 1 1/4)	8
4		JCBB BOLT WITH SPRING WASHER AND FLAT WASHER (M8 x 25mm)	8
5		ALLEN KEY (M5)	1

BOX 2
SIDE RAILS

ITEM	DRAWING	DESCRIPTION	QTY
G		RIGHT SIDE RAIL	1
H		LEFT SIDE RAIL	1

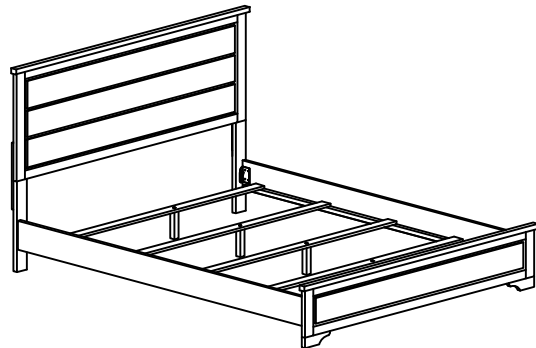

COMPLETED QUEEN BED ASSEMBLY

STEP 1:

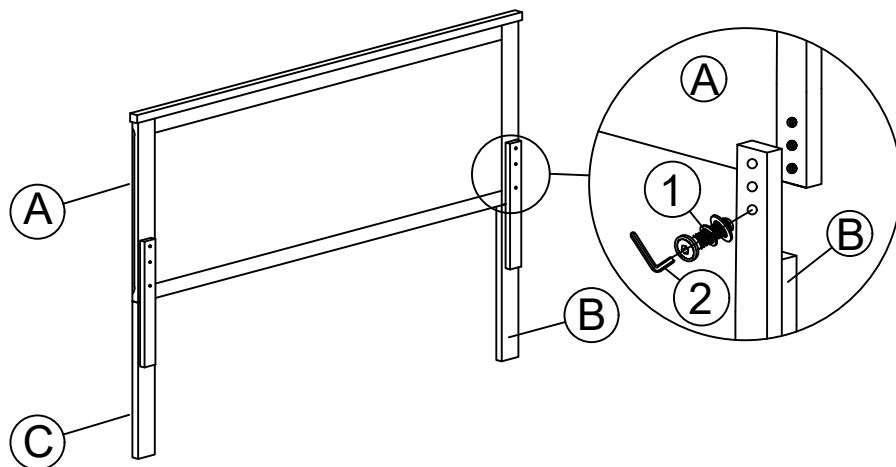

ASSEMBLY INSTRUCTIONS

ITEM NO : B3050-Q-HBFB / B3050-KQ-RAIL
QUEEN BED

STEP 2:

COMPLETED ASSEMBLY

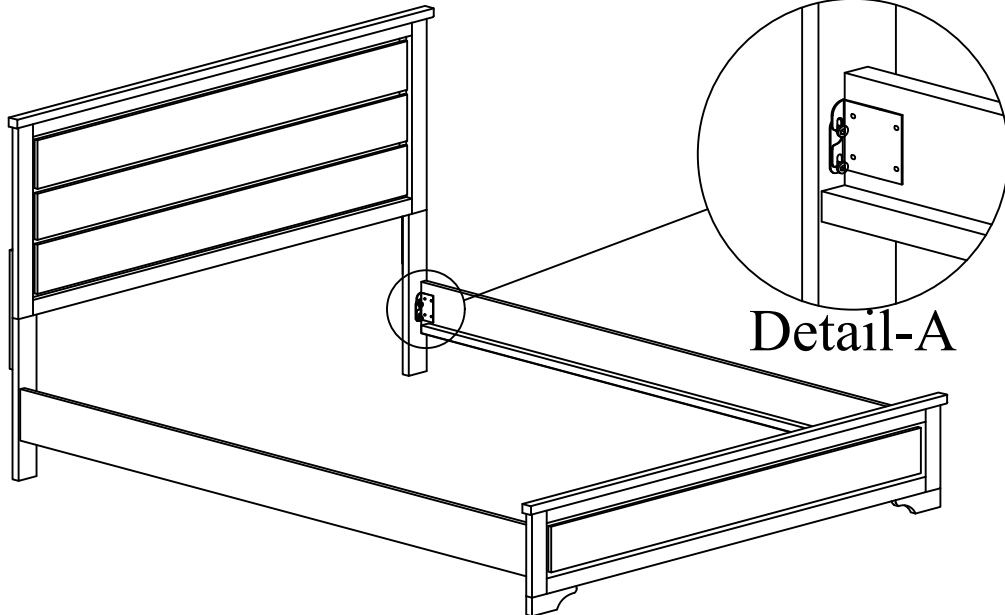
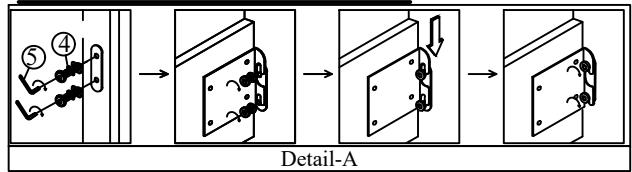

STEP 3:

STEP 3.2:



STEP 3.1: ↑

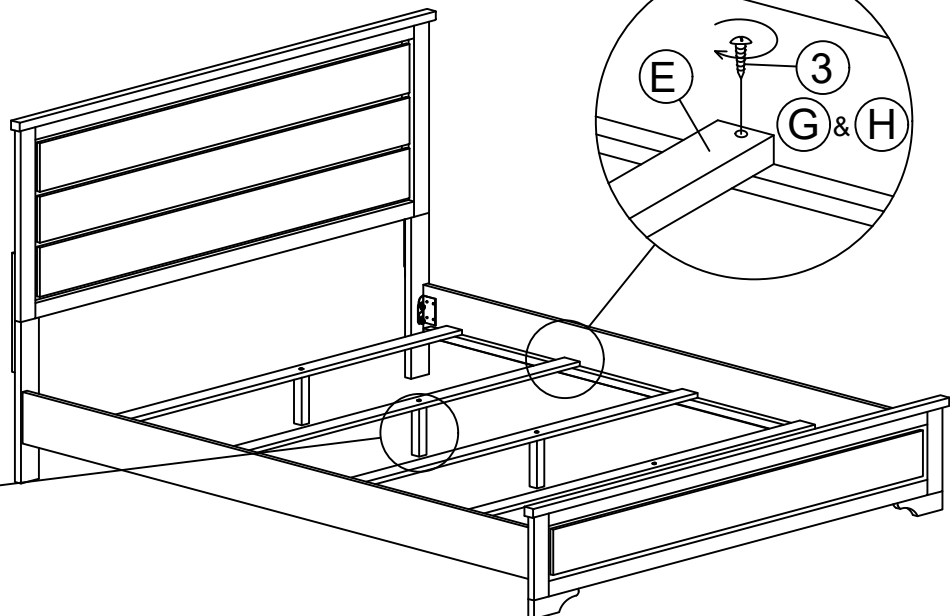
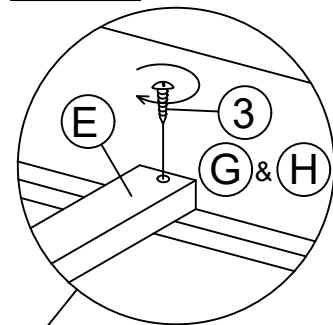
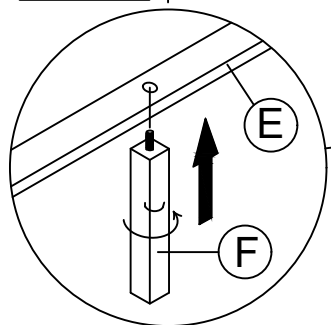

THE HARDWARE IS LOCATED IN THE PACKING ITEMS

NOTE : Periodically check to ensure that all connectors (bolts, screws, etc.) are tight.

CLEANING INSTRUCTION

After assembled, clean & polish the completed parts if necessary with soft cloth and industrial recognized furniture polish

MADE IN MALAYSIA