

ASSEMBLY INSTRUCTIONS

ITEM NO : B3200-F-HBFB / B3200-FT-RAIL
FULL BED

**BOX 1
HEADBOARD, FOOTBOARD AND SLATS**

ITEM	DRAWING	DESCRIPTION	QTY
A		HEADBOARD PANEL	1
B		RIGHT HEADBOARD LEG	1
C		LEFT HEADBOARD LEG	1
D		FOOTBOARD PANEL	1
E		SLAT	3
F		SLAT SUPPORT	3

**BOX 1
HARDWARE LIST**

ITEM	DRAWING	DESCRIPTION	QTY
1		JCBC SCREW (M6 x 40mm)	6
2		SPRING WASHER (M6)	6
3		FLAT WASHER (1/4)	6
4		ALLEN KEY (M4)	1
5		SCREW P/H RATTAN (1/4) (8X1)	6
6		ALLEN KEY (M5)	1
7		JCBC SCREW (M8 X 25MM)	8
8		SPRING WASHER (5/16")	8
9		FLAT WASHER (5/16"X1MM)	8

**BOX 2
SIDE RAILS**

ITEM	DRAWING	DESCRIPTION	QTY
G		SIDE RAIL	2

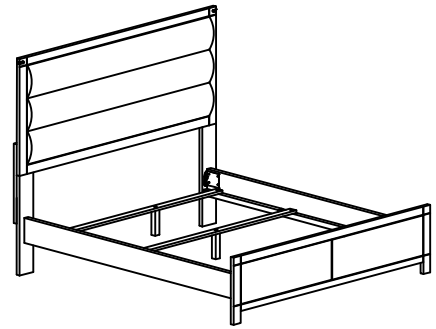

COMPLETED FULL BED ASSEMBLY

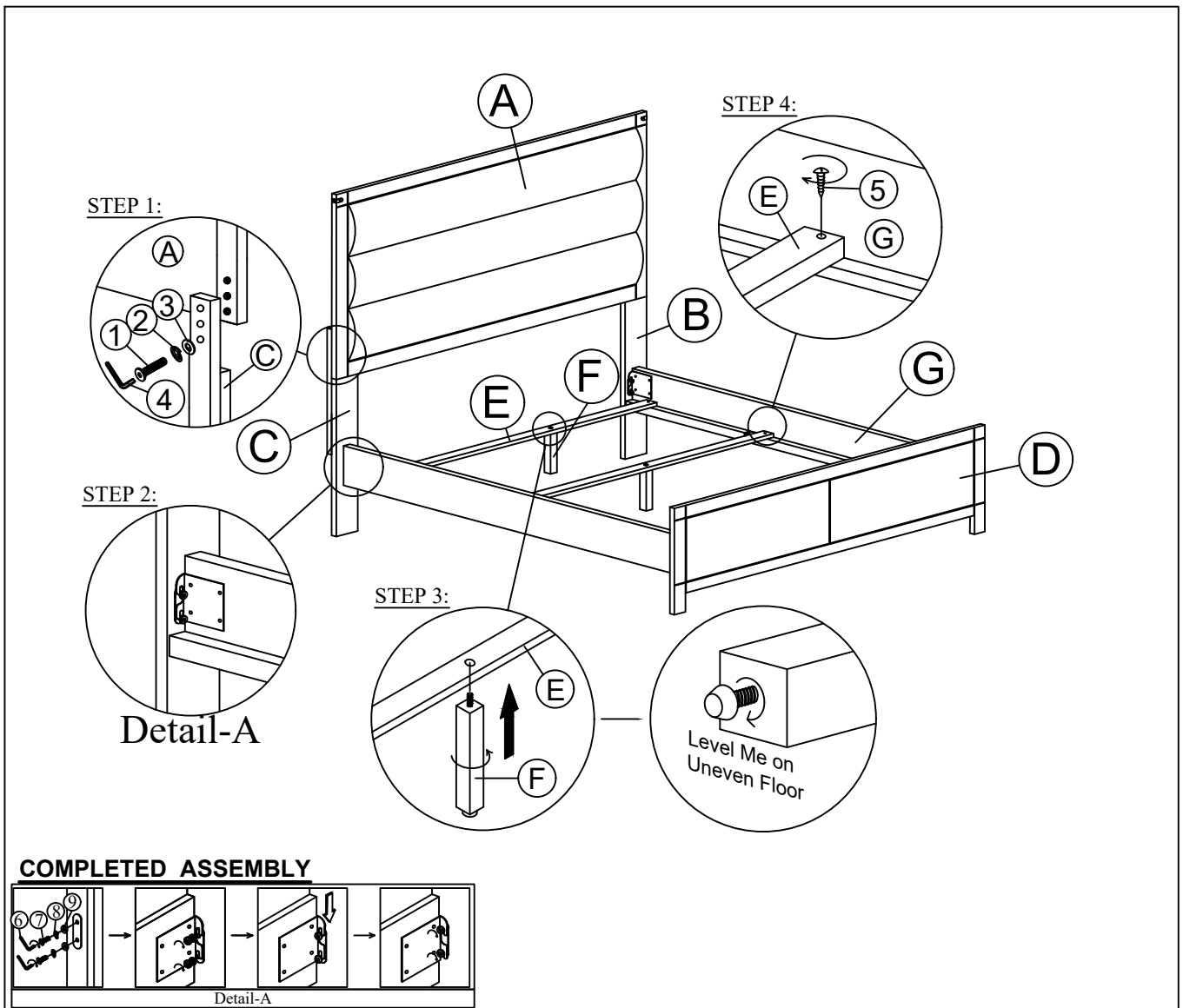

THE HARDWARE IS LOCATED IN THE PACKING ITEMS

NOTE : Periodically check to ensure that all connectors (bolts, screws, etc.) are tight.

CLEANING INSTRUCTION

After assembled, clean & polish the completed parts if necessary with soft cloth and industrial recognized furniture polish

MADE IN MALAYSIA