

# ASSEMBLY INSTRUCTIONS

ITEM NO : B3300-11  
VEDA MIRROR

## BOX OF MIRROR

ITEM	DRAWING	DESCRIPTION	QTY
A		MIRROR	1
B		DRESSER TOP SUPPORT RAIL	2

## BOX OF DRESSER

ITEM	DRAWING	DESCRIPTION	QTY
A		DRESSER	1

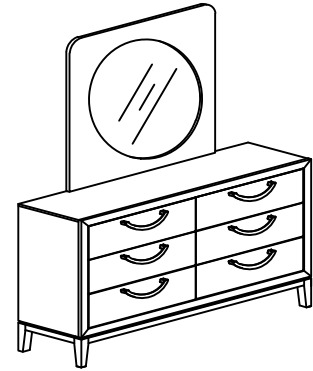

**COMPLETED MIRROR ASSEMBLY**

## BOX OF MIRROR

### HARDWARE LIST

ITEM	DRAWING	DESCRIPTION	QTY
1		JCBC BOLT WITH SPRING WASHER AND FLAT WASHER (M6 x 35mm)	8
2		ALLEN KEY (M4)	1

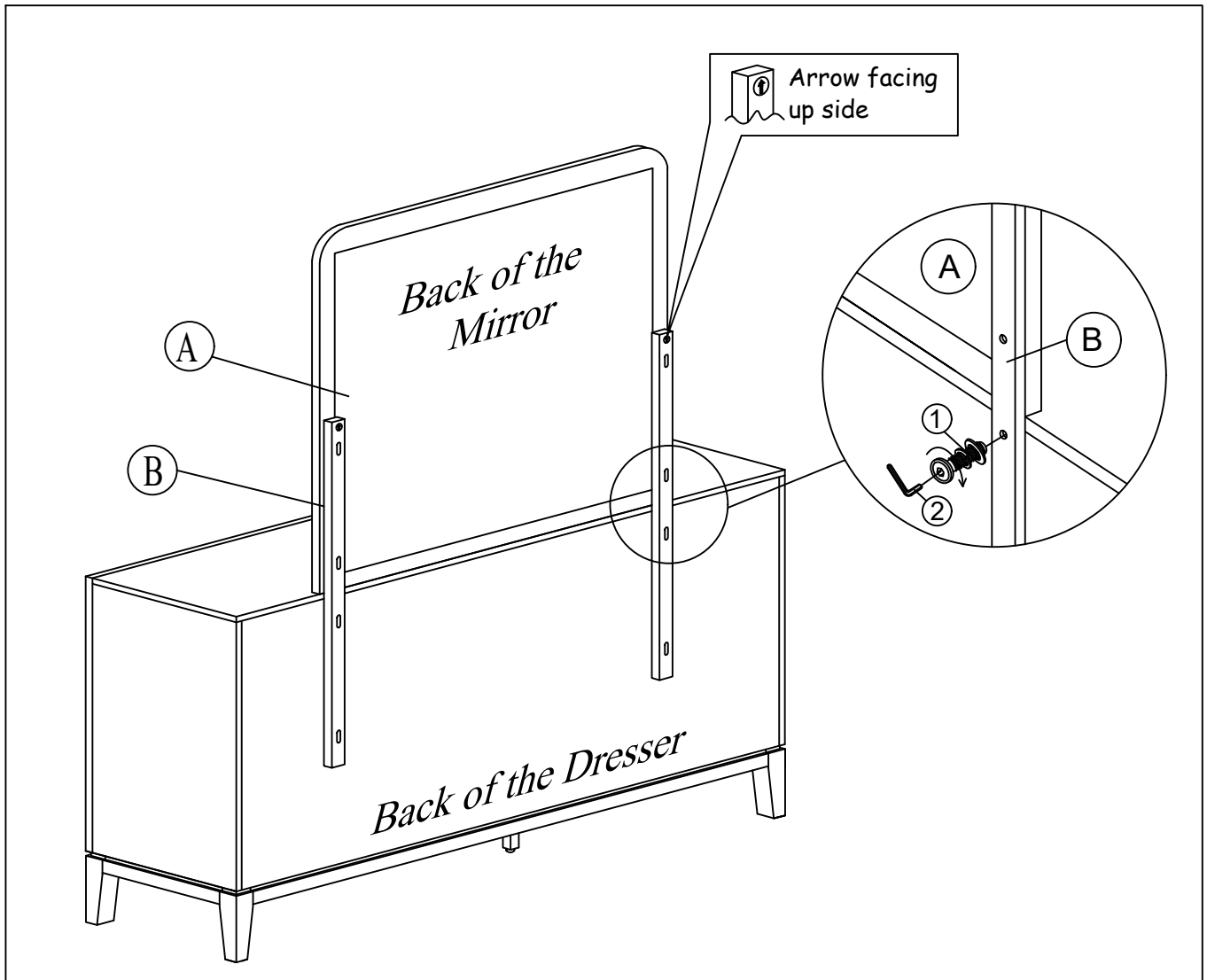

**THE HARDWARE IS LOCATED IN THE PACKING ITEMS**

NOTE : Periodically check to ensure that all connectors (bolts, screws, etc.) are tight.

### CLEANING INSTRUCTION

After assembled, clean & polish the completed parts if necessary with soft cloth and industrial recognized furniture polish

**MADE IN MALAYSIA**