

ASSEMBLY INSTRUCTIONS

CROWNMARK :
B4300/B4310/B4312
TWIN (4+0)

(Box 1)
 BOX OF HEADBOARD & FOOTBOARD

No	ITEM	Qty
A	Headboard	1 pc
B	Headboard Leg (L/R) Nail Leg 770	2 pcs
C	Footboard	1 pc
D	Bed Slats	4 pcs

(Box 2)
 BOX OF SIDE RAIL

No	ITEM	Qty
E	Side Rail	2 pcs

(Box 1)
 HARDWARE LIST

No	ITEM	Qty
1	JCBC M6 x 30mm	6 pcs
2	SPRING WASHER 1/4" Rbw	6 pcs
3	Flat Washer 1/4"ID x 13mmOD Blk	6 pcs
4	ALLEN KEY m4x65mm Blk	1 pc
5	Csk M4 x 32mm	8 pcs
6	ALLEN KEY m5x65mm Blk	1 pc
7	12V+12W+1A Adaptor With ETL Certificate (US)(INSIDE THE BOX WITH RED LABEL)	1 pc

STEP 1 : Attach Headboard Leg (B) to Headboard (A) as shown using JCBC BOLT (1)with Spring Washer (2), Flat washer (3) and securing with ALLEN KEY (4).
 THE HARDWARE IS LOCATED IN THE PACKING ITEM

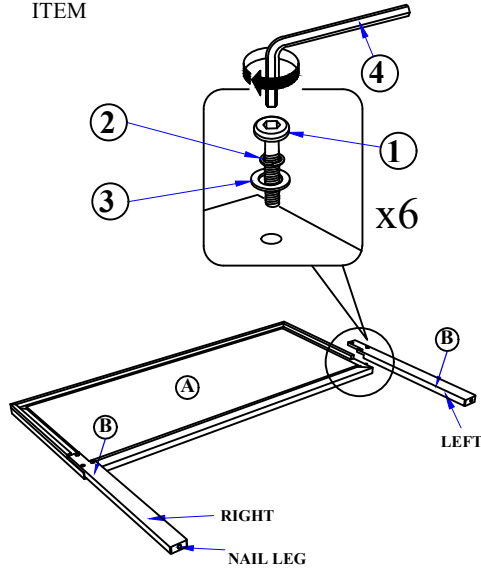

STEP 2 : Hook SIDE RAIL (E) TO HEADBOARD (A) closely and push down to fit. repeat step 2 with other end of rail to hook onto FOOTBOARD (C).

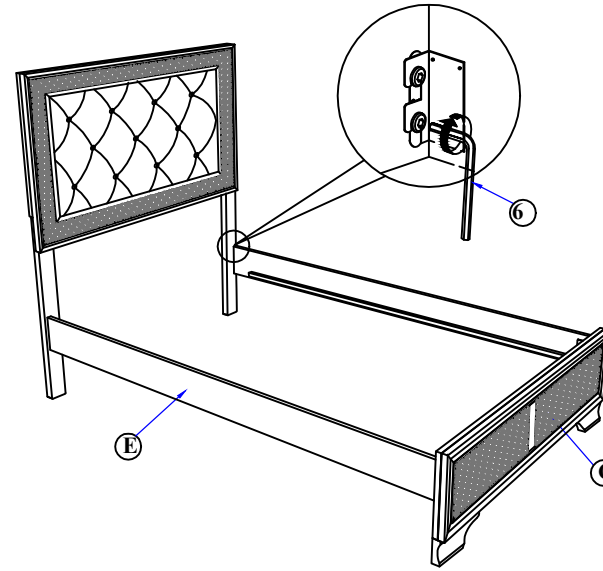

STEP 3 : Tighten the 4 Corner with Allen Key (6) as shown . Install the bed slat (D) to side rail (E) and tighten with Csk Screw (5) as per diagram shown. (NOTE: THE SETUP MUST DONE AT THE DECIDED LOCATION FOR THE BED TO OBTAIN PERFECT STABILITY)

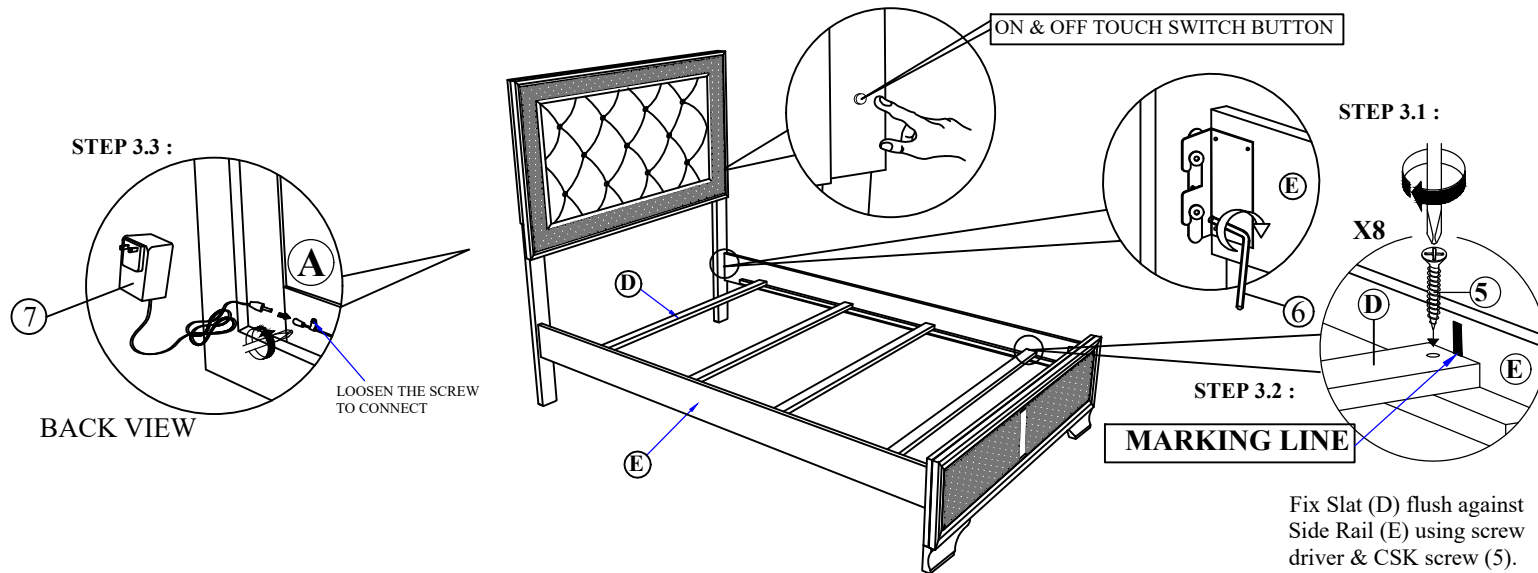

Fix Slat (D) flush against Side Rail (E) using screw driver & CSK screw (5).

NOTE : Periodically check to ensure that all connectors (bolts, screws, etc.) are tight.