

# ASSEMBLY INSTRUCTIONS

**CROWNMARK :**  
**B4300/B4310/B4312**  
**FULL (4+4)**

**(Box 1)**  
 BOX OF HEADBOARD & FOOTBOARD

No	ITEM	Qty
A	Headboard	1 pc
B	Headboard Leg (L/R) Nail Leg 770	2 pcs
C	Footboard	1 pc
D	Bed Slats	4 pcs
E	Bed Slats Support 30x30x225mm	4 pcs

**(Box 2)**  
 BOX OF SIDE RAIL

No	ITEM	Qty
F	Side Rail	2 pcs

**(Box 1)**  
 HARDWARE LIST

No	ITEM	Qty
1	JCBC M6 x 30mm	6 pcs
2	SPRING WASHER 1/4" Rbw	6 pcs
3	Flat Washer 1/4"ID x 13mmOD Blk	6 pcs
4	ALLEN KEY m4x65mm Blk	1 pc
5	Csk M4 x 32mm	8 pcs
6	ALLEN KEY m5x65mm Blk	1 pc
7	12V+12W+1A Adaptor With ETL Certificate (US/INSIDE THE BOX WITH RED LABEL)	1 pc

**STEP 1 :** Attach Headboard Leg ( B ) to Headboard ( A ) as shown using JCBC BOLT ( 1 )with Spring Washer ( 2), Flat washer ( 3) and securing with ALLEN KEY ( 4 ). THE HARDWARE IS LOCATED IN THE PACKING ITEM

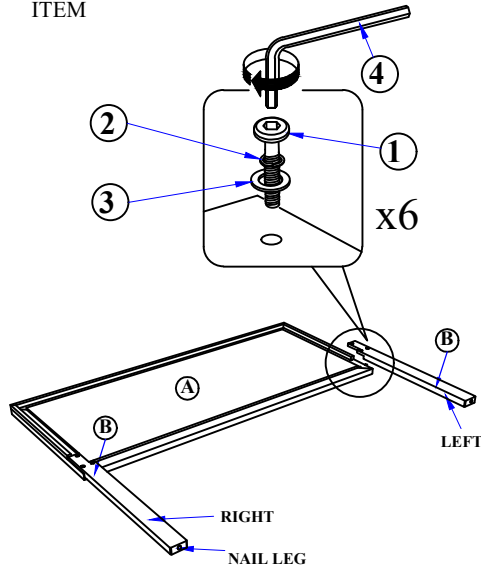

**STEP 2 :** Hook SIDE RAIL ( F ) TO HEADBOARD ( A ) closely and push down to fit. Repeat step 2 with other end of rail to hook onto FOOTBOARD ( C ).

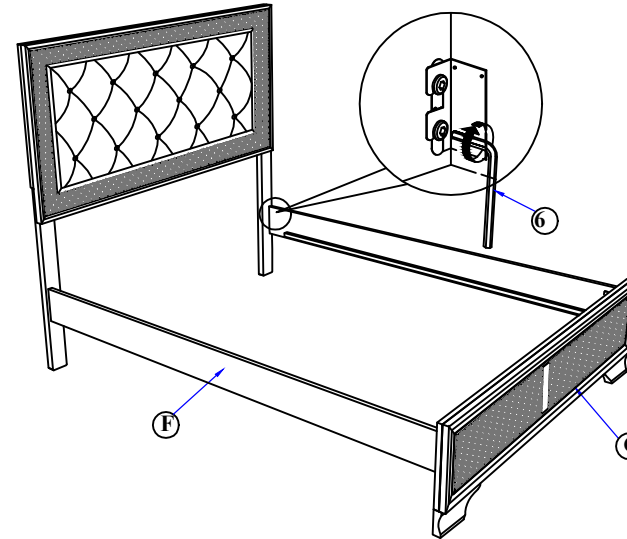

**STEP 3 :** Tighten the 4 Corner with Allen Key ( 6 ). Fix the Bed Slat Support Leg ( E ), to Bed Slat ( D ) as shown . Install the bed slat ( D ) to side rail ( F ) and tighten with Csk Screw ( 5 ) as per diagram shown. (NOTE: THE SETUP MUST BE DONE AT THE DECIDED LOCATION FOR THE BED TO OBTAIN PERFECT STABILITY)

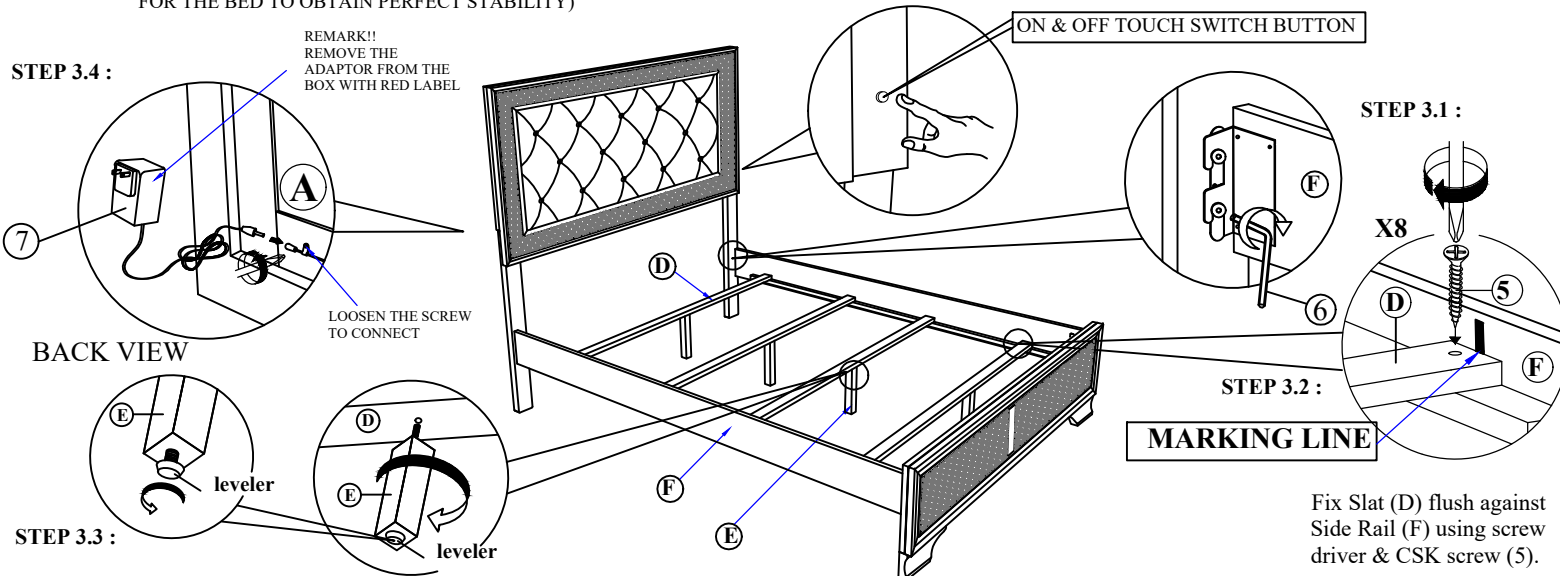

Fix Slat ( D ) flush against Side Rail ( F ) using screw driver & CSK screw ( 5 ).

**NOTE :** Periodically check to ensure that all connectors (bolts, screws, etc.) are tight.