





# ASSEMBLY INSTRUCTIONS

## CROWNMARK : B4350-1 DRESSER

### (BOX 1) BOX OF DRESSER

NO	ITEM	QTY
	DRESSER	
A		1 PC

### (BOX 1) HARDWARE LIST

NO	ITEM	QTY
1	Truss Head Machine Screw m4x28mm Blk 	7 PCS
2	HANDLE 	7 PCS
3	Tipping Restraint 	1 PC

**STEP 1 :** Remove HANDLE ( 2 ) using a Philips head screw driver as shown in illustration STEP - A. Re-install the HANDLE ( 2 ) as per diagram STEP - B. Repeat STEP - A STEP - B until HANDLE ( 2 ) are attached correctly.  
THE HARDWARE IS LOCATED IN THE PACKING ITEM  
THE ANTI- TIPPING HARDWARE IS LOCATED IN THE TOP RIGHT DRAWER.

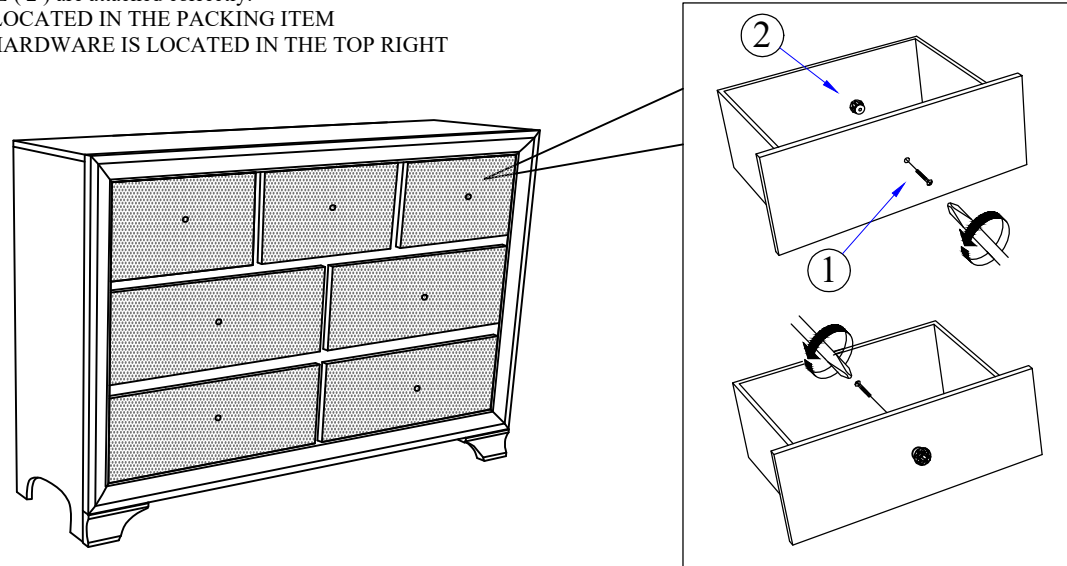

STEP - A

STEP - B

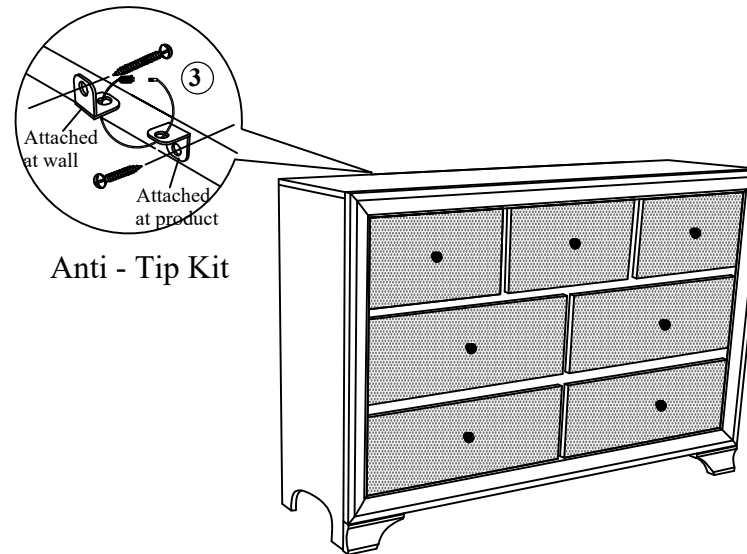

Anti - Tip Kit

**COMPLETED ASSEMBLY**

NOTE : Periodically check to ensure that all connectors (bolts, screws, etc.) are tight.