

ASSEMBLY INSTRUCTION

CROWNMARK
MODEL : B4398-1/B4398-11
DRESSER & MIRROR

(Box 1)
 BOX OF MIRROR

NO	ITEM	Qty
	MIRROR	
A		1 PC



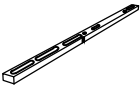

(Box. 2)
 BOX OF DRESSER

NO	ITEM	Qty
	DRESSER	
B		1 PC

(Box. 1)
 BOX OF MIRROR

NO	ITEM	Qty
	MIRROR SUPPORT RAIL	
C		2 PCS

(Box. 1)
 HARDWARE LIST

NO	ITEM	Qty
1	JCBC BOLT M6 x 35MM BLK 	4 PCS
2	JCBC BOLT M6 x 40MM BLK 	4 PCS
3	SPRING WASHER 1/4" RBW 	8 PCS
4	FLAT WASHER 1/4" ID x 19mmOD BLK 	8 PCS
5	ALLEN KEY m4 x 65mm BLK 	1 PC

STEP 1

Draw out mirror support (C) from the carton box.
 THE HARDWARE IS LOCATED IN THE PACKING ITEM

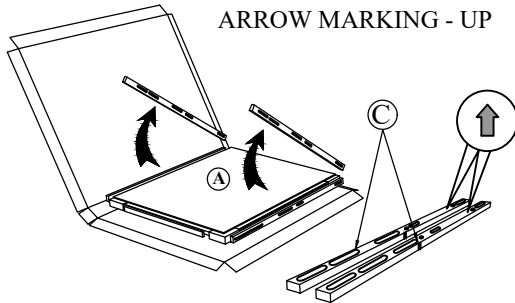

STEP 2 : Align & fasten mirror support (C) to the back of mirror (A) using short JCBC bolt(1), spring washer (3) & flat washer (4). DO NOT FULLY TIGHTEN AT THIS STEP.

Note : Make sure arrow marking of the mirror support (C) is aligned up.

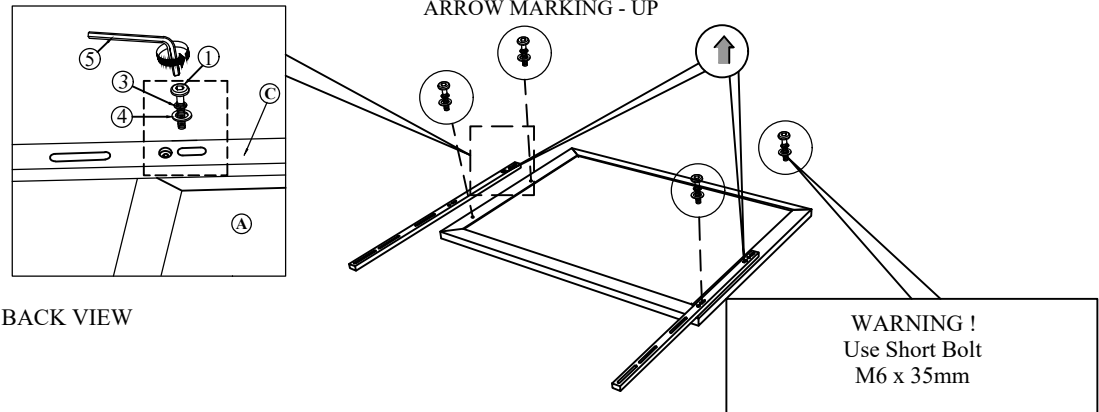

STEP 3 : Place mirror (A) on top of dresser (B). Align & fasten mirror support (C) to the back of dresser (B) using long JCBC bolt (2) , spring washer (3) & flat washer (4) THEN FULLY TIGHTEN ALL THE BOLTS AT STEP 2 & 3 WITH ALLEN KEY (5).

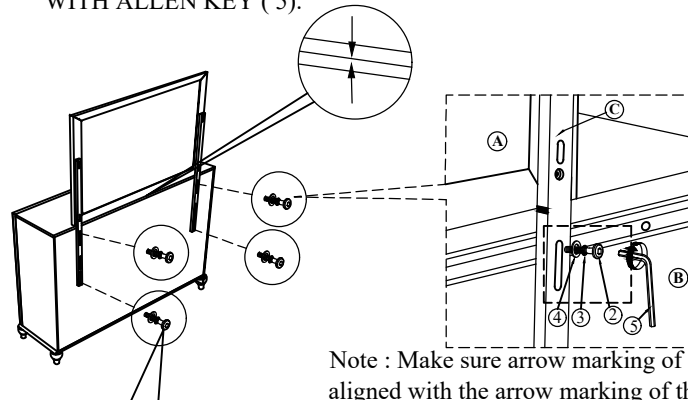

Note : Make sure arrow marking of the mirror support is aligned with the arrow marking of the center of the dresser as show in drawing.

**HARDWARE SET IS IN 1857-6 FOR ASSEMBLY

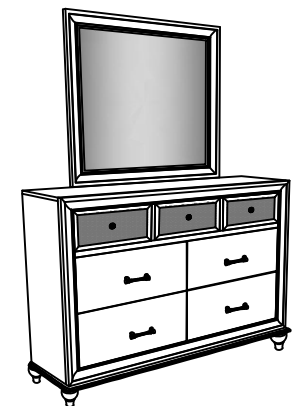

COMPLETED ASSEMBLY

NOTE : Periodically check to ensure that all connectors (bolts, screws, etc.) are tight.