

# ASSEMBLY INSTRUCTION

## MODEL : B4511-Q-BED QUEEN (4+4)

(BOX 1)  
BOX OF HEADBOARD/FOOTBOARD  
/SIDE RAIL

NO	ITEM	QTY
A	HEADBOARD	1
B	FOOTBOARD	1
C	HEADBOARD LEG	2
D	BED SLATS	4
E	BED SLATS SUPPORT	4
F	RIGHT SIDE RAILS	2
G	LEFT SIDE RAILS	2
H	BED SIDE LEG	2

(BOX 1)  
HARDWARE LIST

NO	ITEM	QTY
1	ALLEN WRENCH M4 X 65MM BLK	1
2	JCBC 1/14" BLK M6 X 35MM BLK 1/14"IDX13MMOD BLK	4
3	JCBC 1/14" BLK M6 X 35MM BLK 1/14"IDX19MMOD BLK	8
4	FLAT HEAD SCREW M4 X 32MM BLK	16
5	ALLEN WRENCH M5 X 65MM BLK	1

### STEP 1

STEP 1:1 Attach the Headboard Leg (C) to Headboard (A) as shown using JCBC Bolt (2) and fasten with Allen Wrench (1).

STEP 1:2 Fix the Headboard Leg (C) by using Flat Head Chipboard Screw (4) as shown

REMARK:THE HARDWARE IS LOCATED IN THE PACKING ITEM

### STEP 1:2

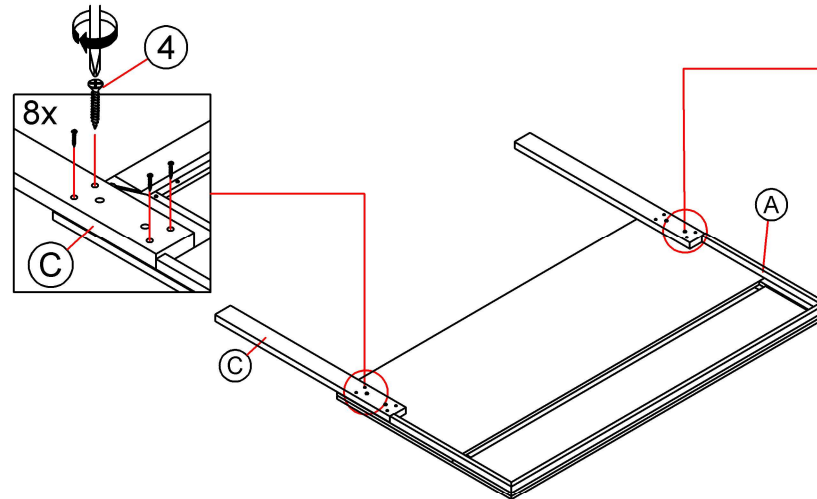

### STEP 1:1

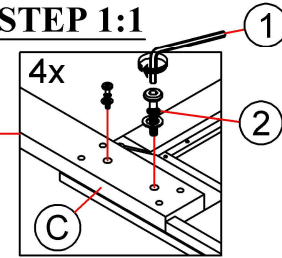

### STEP 2

Attach Right Side Rail (F) and Left Side Rail (G) to the Bed Side Rail Leg (H) as shown using JCBB Bolt (3) and securing with Allen Key (1) by outside Right Side Rail (F) and Left Side Rail (G)

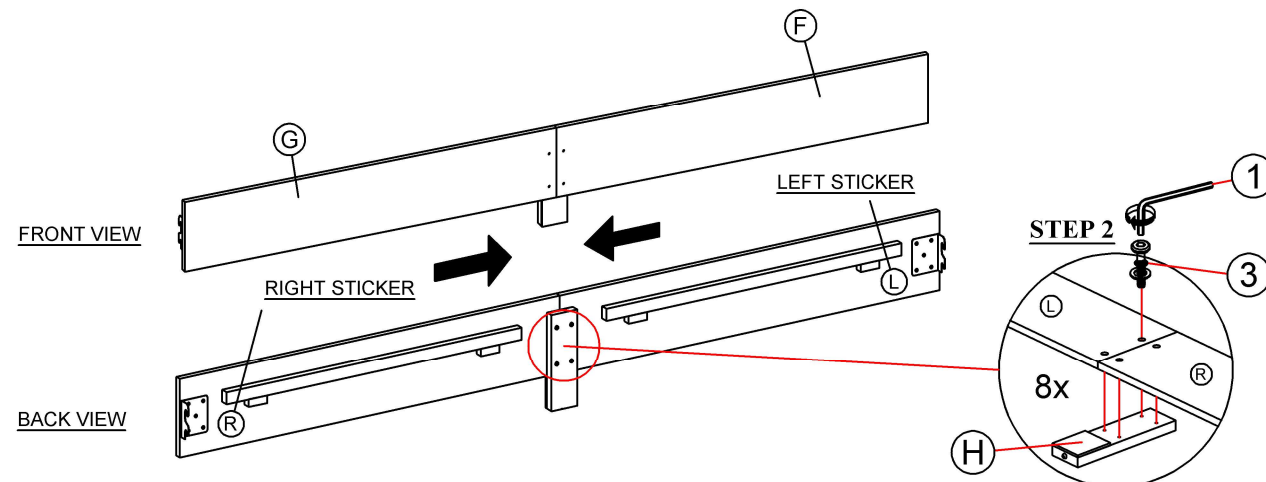

NOTE : PERIODICALLY CHECK TO ENSURE THAT ALL CONNECTORS (BOLTS,SCREWS,ETC.) ARE TIGHT.

# ASSEMBLY INSTRUCTION

## STEP 3

STEP 3:1 loosen the bolt on Headboard Leg (C) and Hook the Side Rails (F)&(G) to Headboard Leg (C) closely and push down to fit.

STEP 3:2 Retighten the bolt using an Allen Wrench (5) as shown. Repeat the same step with other end of rail to hook onto Footboard (B).

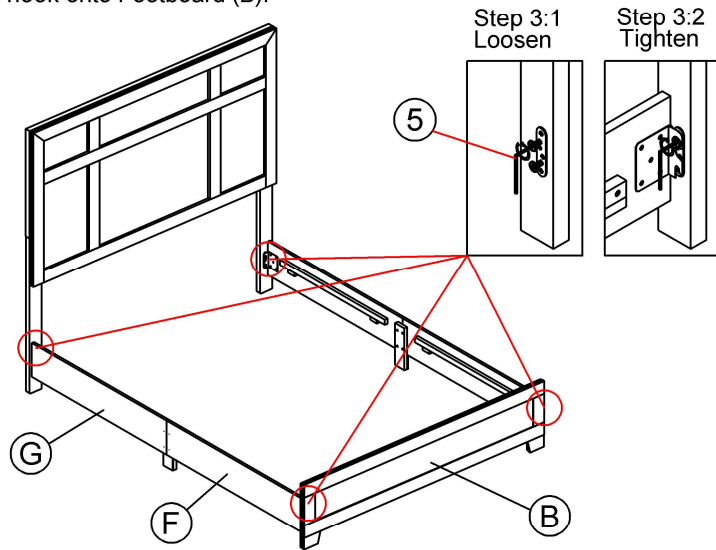

## STEP 4

STEP 4:1 Fix the Bed Slats (D) by push closely to Right Side Rail (F) and Left Side Rail (G) by using Flat Head Chipboard Screw (4) as shown. Bed assembly should be done in final location to ensure stability.

STEP 4:2 Fix the Bed Slats Support (E) to Bed Slats (D) as Shown, Loosen or Tighten the Adjuster as necessary to level the Bed

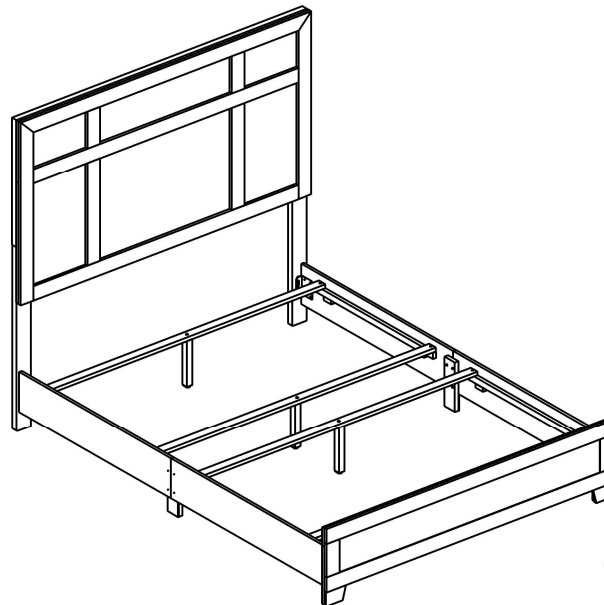
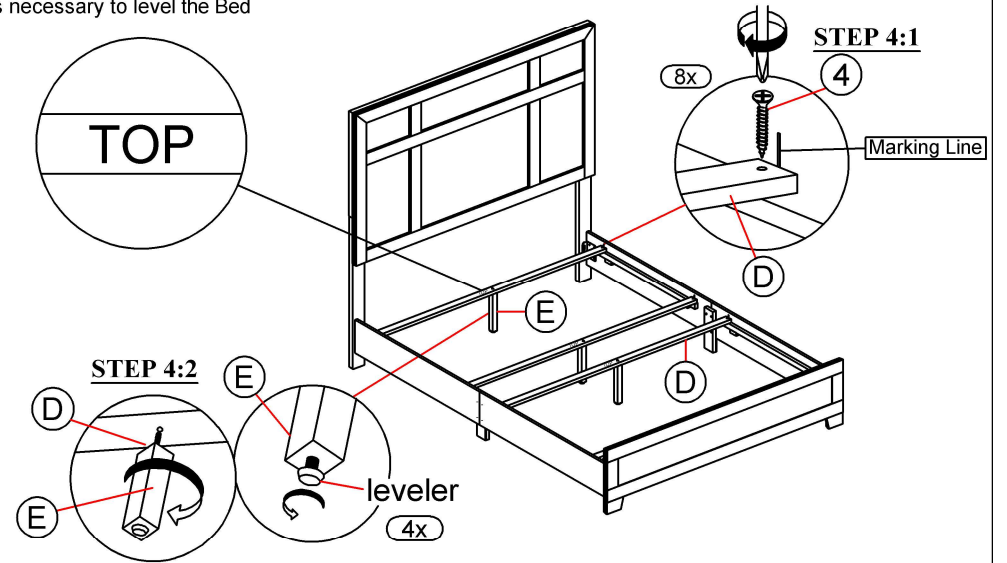

**COMPLETED  
ASSEMBLY**