

ASSEMBLY INSTRUCTION

CROWNMARK
B4670-1 /
B4670-11 DRESSER & MIRROR

(Box 1)
 BOX OF MIRROR

NO	ITEM	Qty
A	MIRROR	1 PC
B	MIRROR SUPPORT RAIL	2 PCS

(Box. 2)
 BOX OF DRESSER

NO	ITEM	Qty
C	DRESSER	1 PC

(Box. 1)
 HARDWARE LIST

NO	ITEM	Qty
1	JCBC BOLT M6 x 35MM BLK	8 PCS
2	SPRING WASHER 1/4" RBW	8 PCS
3	FLAT WASHER 1/4" ID x 19mmOD BLK	8 PCS
4	ALLEN KEY m4 x 65mm BLK	1 PC

STEP 1

Draw out mirror support (B) from the carton box. THE HARDWARE IS LOCATED IN THE PACKING ITEM

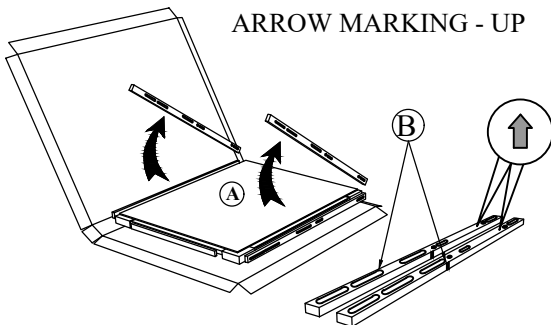

STEP 2 : Align & fasten mirror support (B) to the back of mirror (A) using short JCBC bolt(1), spring washer (2) & flat washer (3). DO NOT FULLY TIGHTEN AT THIS STEP.

Note : Make sure arrow marking of the mirror support (B) is aligned up.

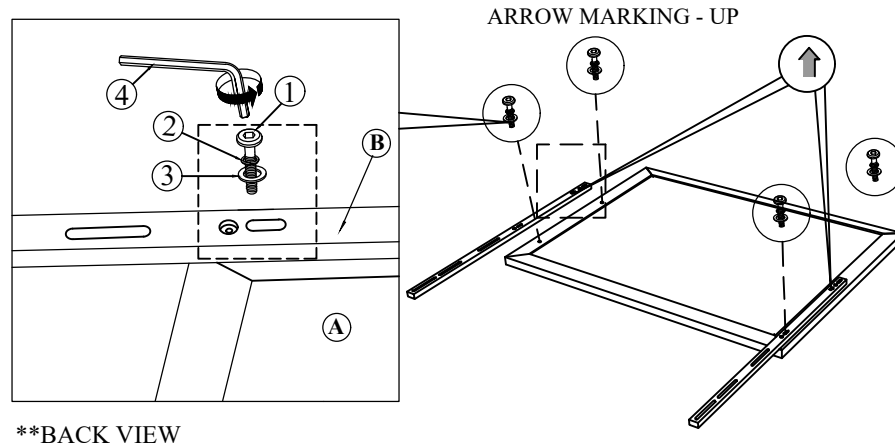

STEP 3 : Place mirror (A) on top of dresser (C). Align & fasten mirror support (B) to the back of dresser (C) using long JCBC bolt (1) , spring washer (2) & flat washer (3) THEN FULLY TIGHTEN ALL THE BOLTS AT STEP 2 & 3 WITH ALLEN KEY (4).

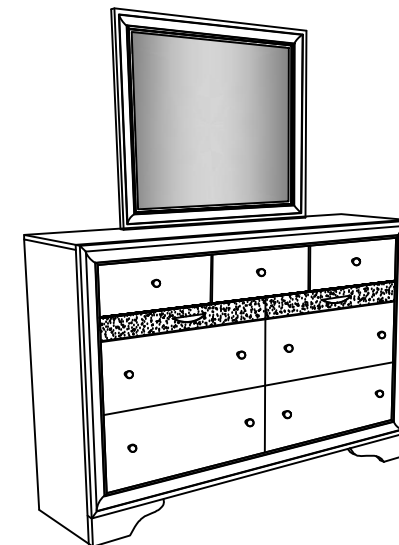
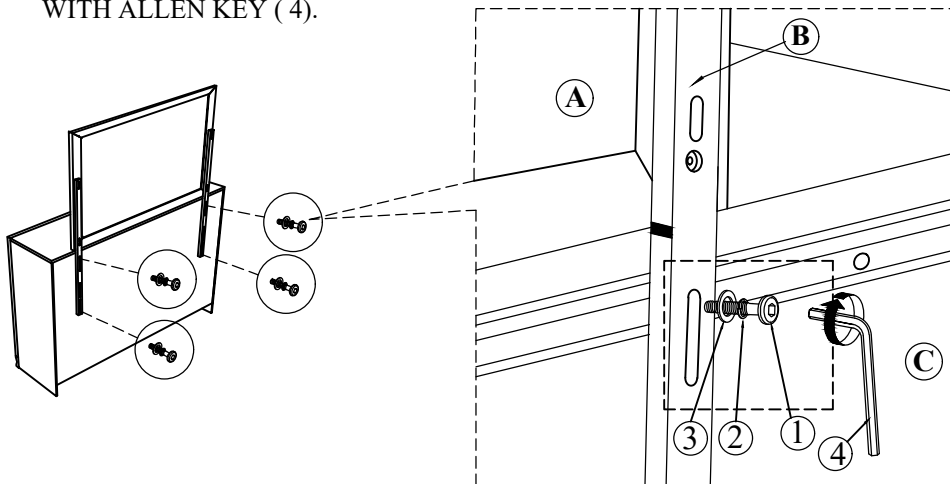

COMPLETED ASSEMBLY

NOTE : Periodically check to ensure that all connectors (bolts, screws, etc.) are tight.