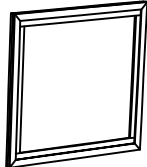

# ASSEMBLY INSTRUCTIONS

**MODEL : B4690-1 & B4690-11  
DRESSER & MIRROR**

**(BOX 1)**

BOX OF MIRROR

NO	ITEM	QTY
	MIRROR	
A		1 PC

**(BOX 2)**

BOX OF DRESSER

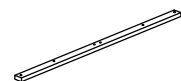
NO	ITEM	QTY
	DRESSER	
B		1 PC
	MIRROR SUPPORT	
C		2 PCS

**(BOX 1)**

HARDWARE LIST

BOX OF MIRROR

NO	ITEM	QTY
1	FLAT HEAD CHIPBOARD SCREW m4 x 32mm RBW 	10 PCS

**STEP 1 :** Cut of the Raffia String from the back of DRESSER ( B ).  
THE HARDWARE IS LOCATED IN THE PACKING ITEM.

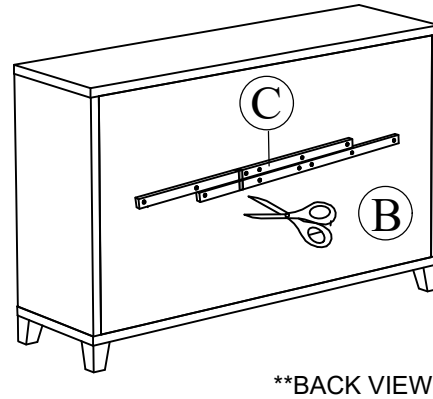

**STEP 2 :** Turn the MIRROR SUPPORT RAIL ( C ) upward at the back of DRESSER ( B ), then Tighten with CSK SCREW ( 1 ). Place the MIRROR FRAME ( A ) on the top of DRESSER ( B ). Tighten with Flat Head Chipboard Screw ( 1 ).

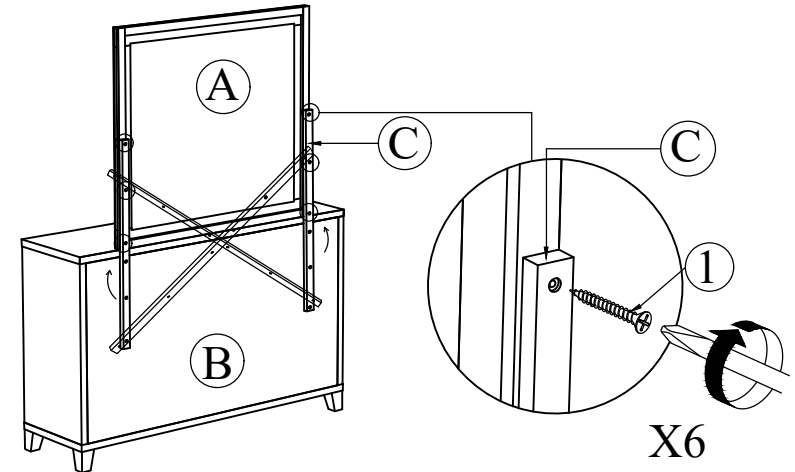

**STEP 3 :** Tighten the Flat Head Chipboard Screw ( 1 ) as shown.

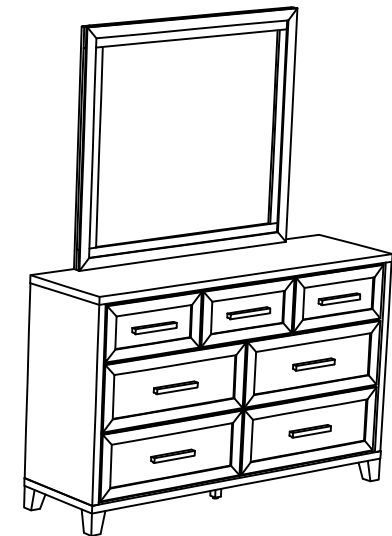
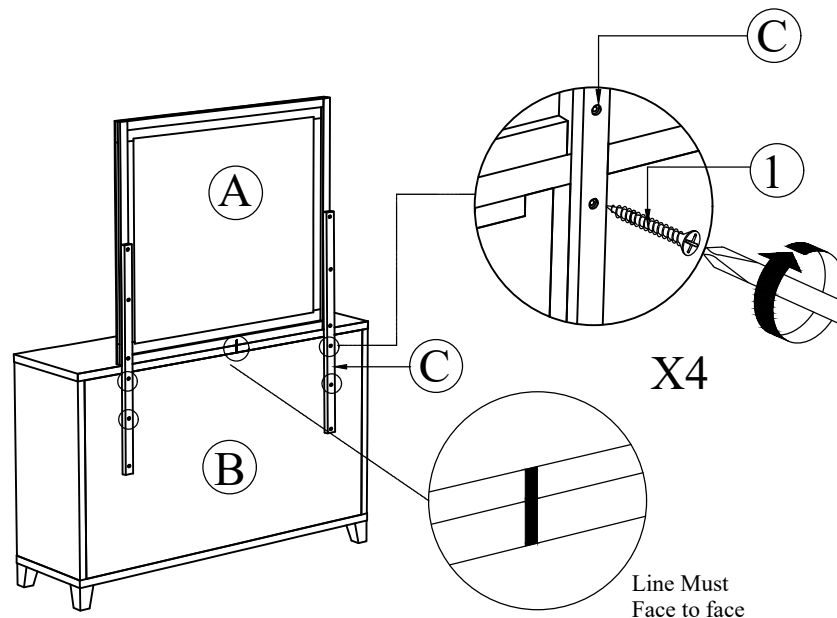

**COMPLETED ASSEMBLY**

NOTE : Periodically check to ensure that all connectors (bolts, screws, etc.) are tight.