

ASSEMBLY INSTRUCTIONS

**CROWNMARK :
B4710-Q-HBFB/B4710-Q-RAIL
QUEEN BED (4+4)**

(BOX 1)

BOX OF HEADBOARD

NO	ITEM	QTY
A	HEADBOARD	1 PC
B	FOOTBOARD	1 PC
C	HB LEG L&R	2 PCS

(BOX 2)

BOX OF SIDE RAIL

NO	ITEM	QTY
D	SIDE RAIL	2 PCS
E	BED SLAT	4 PCS
F	BED SLAT SUPPORT	4 PCS

(BOX 1)

HARDWARE LIST

NO	ITEM	QTY
1	JCBC BOLT M6 x 30MM BLK	6 PCS
2	SPRING WASHER 1/4" RBW	6 PCS
3	FLAT WASHER 1/4" ID x 13mmOD BLK	6 PCS
4	ALLEN KEY m4 x 65mm BLK	1 PC

(BOX 2)

HARDWARE LIST

NO	ITEM	QTY
5	FLAT HEAD CHIPBOARD SCREW m4 x 32mm RBW	8 PCS

STEP 1 : Attach Head Board Leg (C) to Head Board (A) as shown using JCBC BOLT (1)with Spring Washer (2), Flat washer (3) and securing with ALLEN KEY (4).

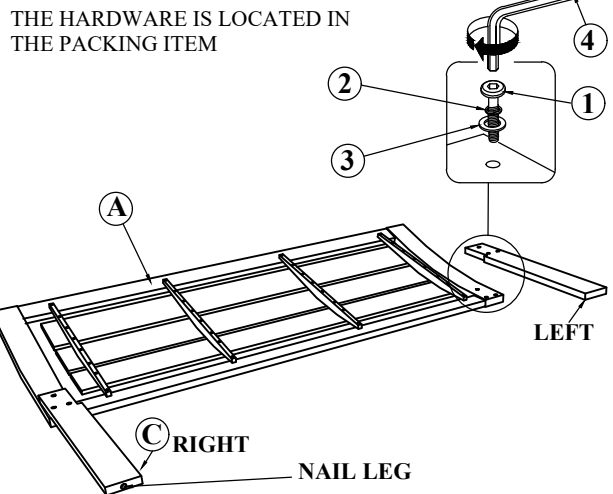

STEP 2 : Hook SIDE RAIL (D) TO HEAD BOARD (A) closely and push down to fit. repeat step 2 with other end of rail to hook onto FOOTBOARD (B).

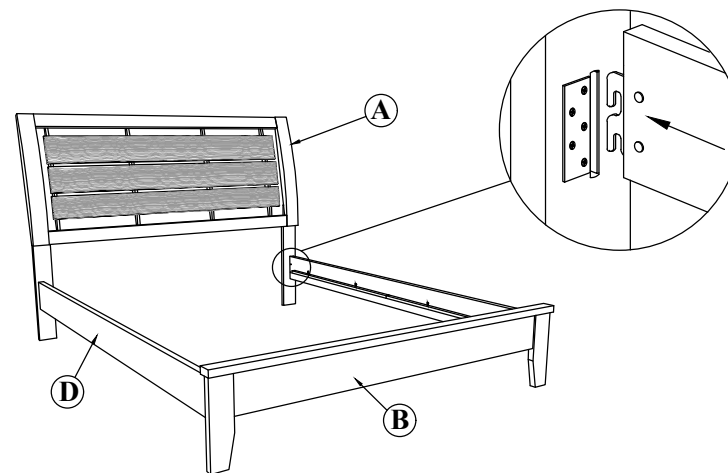

STEP 3 : Fix the Bed Slats Support (F) to Bed Slats (E) as Shown and fix the Bed Slats to Side Rail (D) by using Flat Head Chipboard Screw (5). Loosen or Tighten the Adjuster as necessary to level the bed. Bed assembly should be done in final location to ensure stability.

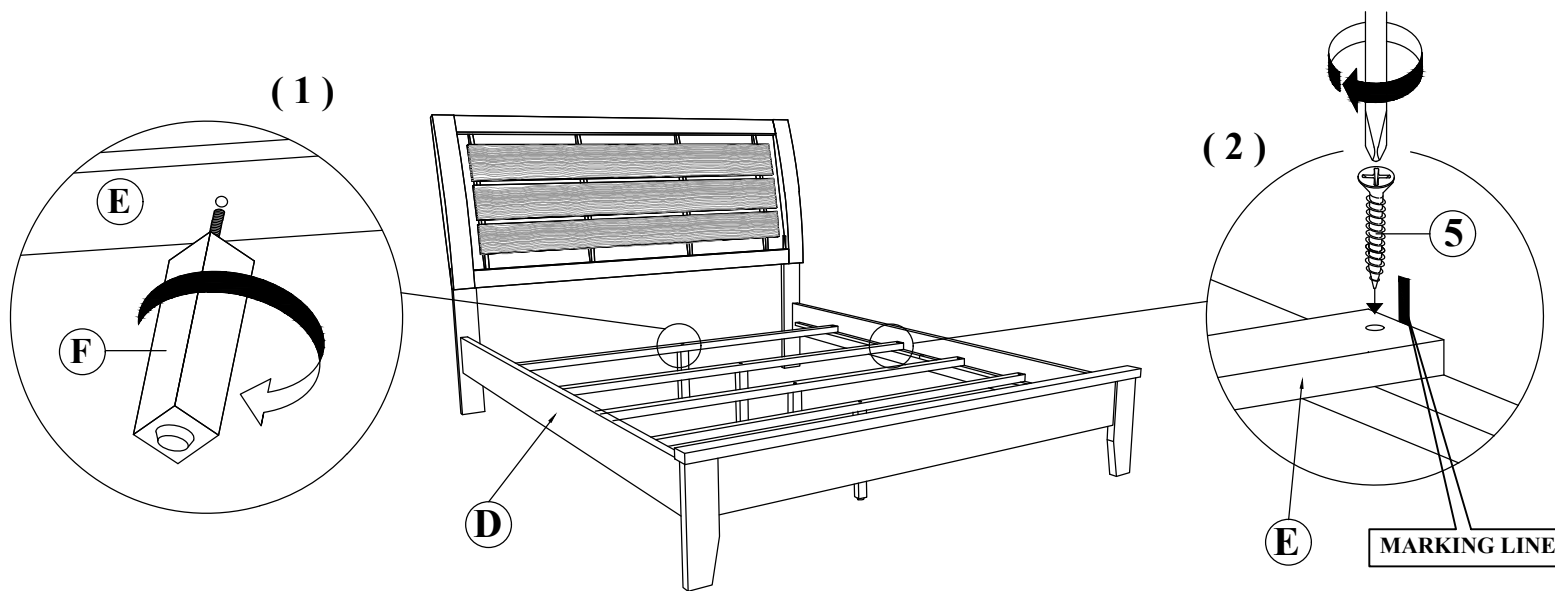

NOTE : Periodically check to ensure that all connectors (bolts, screws, etc.) are tight.