

# ASSEMBLY INSTRUCTIONS

**CROWNMARK  
MODEL :B4800-1/ B4800 -11  
DRESSER & MIRROR**

(Box 1)  
BOX OF MIRROR

| NO | ITEM                                      | QTY   |
|----|---|-------|
| A  | MIRROR                                    | 1 PC  |
| B  | MIRROR SUPPORT RAIL<br>WITH ARROW MARKING | 2 PCS |

(Box 2)  
BOX OF DRESSER

| NO | ITEM    | QTY  |
|----|---------|------|
| C  | DRESSER | 1 PC |

(Box 1)  
HARDWARE LIST

| NO | ITEM                                | QTY   |
|----|-------------------------------------|-------|
| 1  | JCBC BOLT M6 x 35MM<br>BLK          | 4 PCS |
| 2  | JCBC BOLT M6 x 40MM<br>BLK          | 4 PCS |
| 3  | SPRING WASHER 1/4"<br>RBW           | 8 PCS |
| 4  | FLAT WASHER 1/4" ID x<br>19mmOD BLK | 8 PCS |
| 5  | ALLEN KEY m4 x 65mm<br>BLK          | 1 PC  |

STEP 1 : Draw out mirror support (B) from the carton box.  
THE HARDWARE IS LOCATED IN THE PACKING ITEM

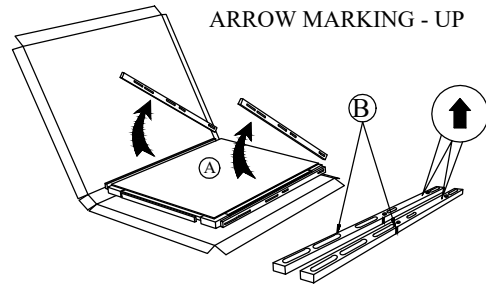

STEP 2 : Align & fasten mirror support (B) to the back of mirror (A) using short JCBC bolt(1),spring washer (3) & flat washer (4). DO NOT FULLY TIGHTEN AT THIS STEP.

Note : Make sure arrow marking of the mirror support (C) is aligned up.

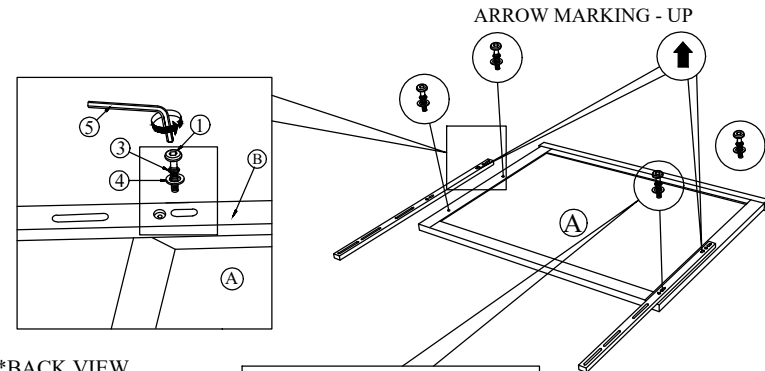

\*\*BACK VIEW

WARNING !  
USE SHORT BOLT M6 x 35mm



STEP 3 :

Place mirror (A) on top of dresser (C). Align & fasten mirror support (B) to the back of dresser (C) using long JCBC bolt (2) , spring washer (3) & flat washer (4) THEN FULLY TIGHTEN ALL THE BOLTS AT STEP 2 & 3 WITH ALLEN KEY ( 5).

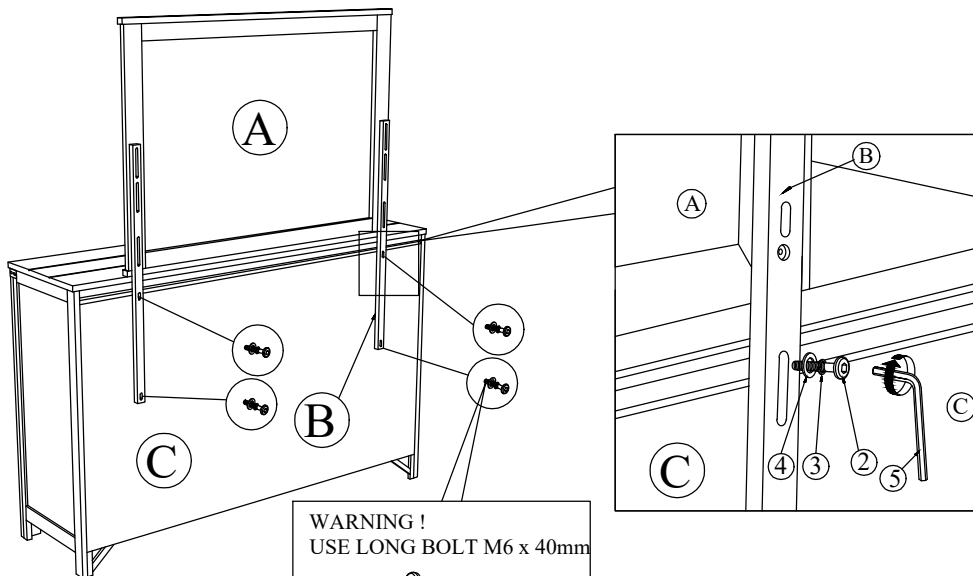

WARNING !  
USE LONG BOLT M6 x 40mm

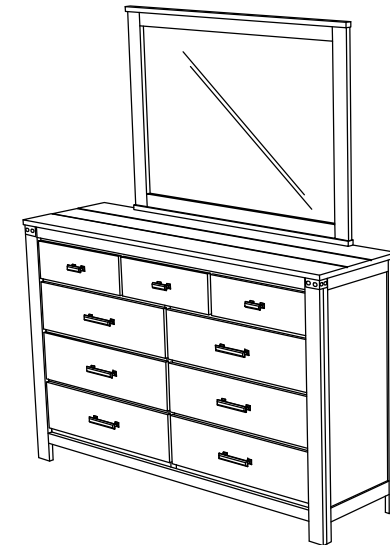

**COMPLETED  
ASSEMBLY**

NOTE : Periodically check to ensure that all connectors (bolts, screws, etc.) are tight.