



# ASSEMBLY INSTRUCTIONS

**CROWNMARK  
MODEL : B4810  
QUEEN BED (4 + 4)**



**(BOX 1)**

**BOX OF HEADBOARD**

NO	ITEM	QTY
A	Headboard 	1
B	Headboard Leg (L&R) 	2

**(BOX 2)**

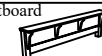
**BOX OF FOOTBOARD**

NO	ITEM	QTY
C	Footboard 	1
D	Slat 	4
E	Slat support 	4



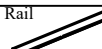

**(BOX 3)**

**BOX OF SIDE RAIL**

NO	ITEM	QTY
F	Side Rail 	2

**(BOX 1)**

**HARDWARE LIST**

NO	ITEM	QTY
1	JCBC BOLT M6 x 35MM 	6 PCS
2	SPRING WASHER 1/4" RBW 	6 PCS
3	FLAT WASHER 1/4" ID x 13mmOD BLK 	6 PCS
4	ALLEN KEY M4 x 65MM 	1 PCS

**(BOX 2)**

**HARDWARE LIST**

NO	ITEM	QTY
5	CSK SCREW M4 x 32MM RBW 	8 PCS

**STEP 1 :** Attach Head Board Leg ( B ) to Head Board ( A ) as shown using JCBC BOLT ( 1 ) , Spring Washer ( 2 ) , Flat Washer ( 3 ) and securing with ALLEN KEY ( 4 )  
THE HARDWARE IS LOCATED IN THE PACKING ITEM

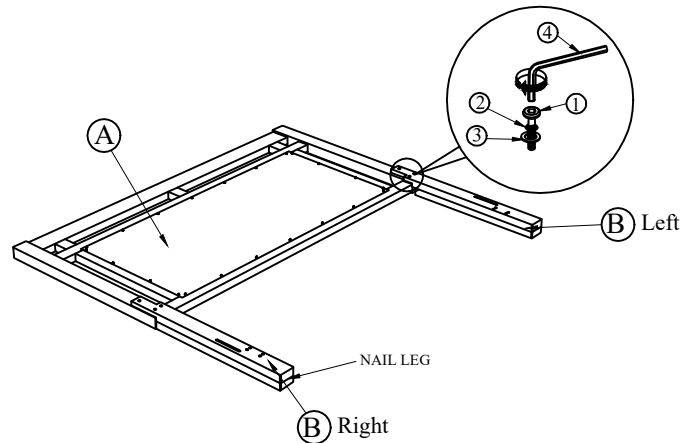

**STEP 2 :** Hook SIDE RAIL ( F ) TO HEAD BOARD ( A ) closely and push down to fit. repeat step 2 with other end of rail to hook onto FOOTBOARD ( C ).

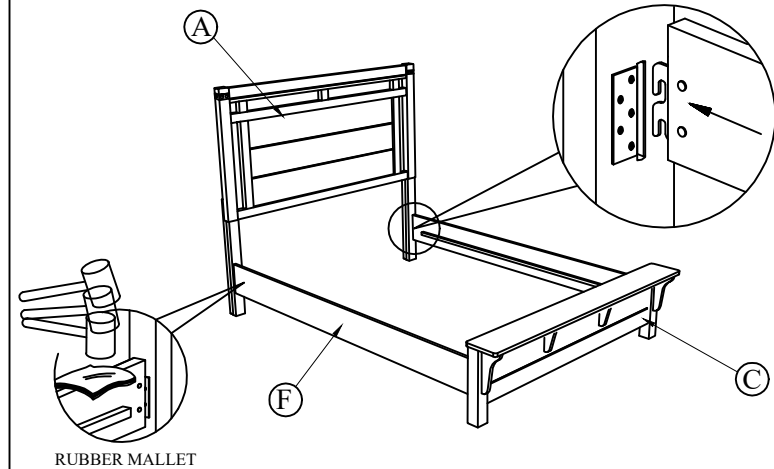

**STEP 3 :** Fix the Bed Slats Support ( E ) to Bed Slats ( D ) as Shown and fix the Bed Slats to Side Rail ( F ) by using Flat Head Chipboard Screw ( 5 ). Loosen or Tighten the Adjuster as necessary to level the bed. Bed assembly should be done in final location to ensure stability.

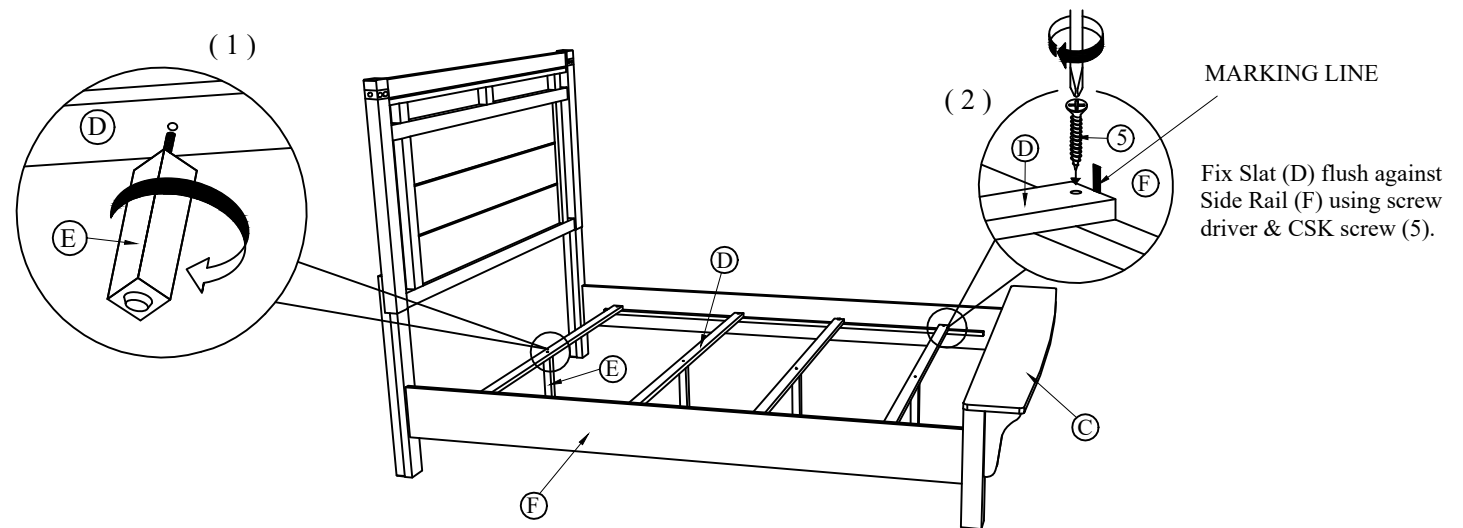

**NOTE :** Periodically check to ensure that all connectors (bolts, screws, etc.) are tight.