













# ASSEMBLY INSTRUCTIONS

**CROWNMARK**  
**MODEL: B4850BK/B4850WH-9L-BASE**  
**B4850BK/B4850WH-9L-TOP**  
**DRESSING TABLE**

**(Box 1)**  
**PART LIST DRESSING TABLE**

No	ITEM	Qty
A	Center Dressing Table 	1 pc
B	Side Dressing Table (L) 	1 pc
C	Side Dressing Table (R) 	1 pc
D	Dressing Table Bottom Back Panel 	1 pc

**(Box 1)**  
**HARDWARE LIST DRESSING TABLE**

No	ITEM	Qty
1	Flat Head Chipboard Screw m4x32mm Rbw 	7 pcs
2	JCN Nut m6x12mm Rbw 	4 pcs
3	Allen Key m4x65mm Blk 	1 pc
4	JCBC Bolt m6x30mm Blk 	4 pcs
5	Wood Dowel 8mmx20mm 	4 pcs
6	Handle (Top Drawer Only) 	3 pcs
7	Truss Head Machine Screw m4x35mm Blk 	3 pcs
8	Door Bubble D7mmx1.5mm Transparent 	12 pcs

**(Box 2)**  
**PART LIST DRESSING TABLE GLASS**

No	ITEM	Qty
E	Dressing Table Top Glass 	1 pc

**REMARKS:**  
 THE HARDWARE IS LOCATED IN THE PACKING ITEM

**STEP 1 :** Insert dowel (5) to Center Dressing Table (A) as shown and push together Dressing Table (B) & (C) with JCN Nut (2), JCBC Bolt set (4) and tighten them by using Allen key (3). (Please Do Not Fully Tighten within this steps).

**STEP 2 :** Repeat same steps for the next Side Dressing Table Right (C) assembly.

**WARNING! : Need two Peoples for assembly process.**

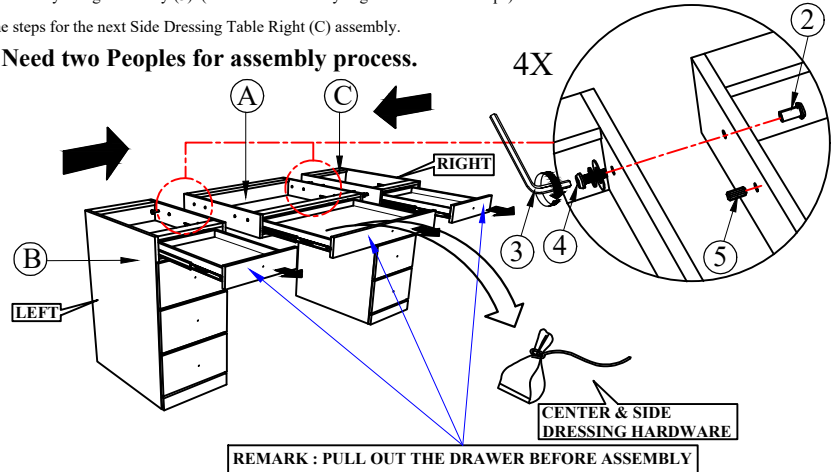

**STEP 3 :** Assemble the Dressing Table Bottom (D) at the back of Dressing Table with CSK Screw (1) and tighten them by using Screw Driver. (NOT PROVIDED)

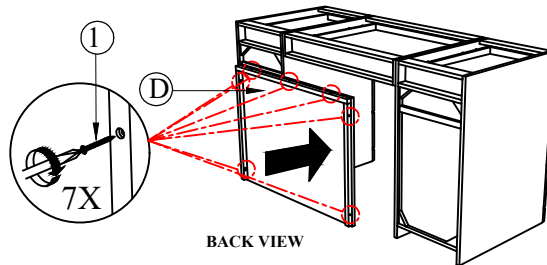

# ASSEMBLY INSTRUCTIONS

**STEP 4 :** Take out the plastic hardware pack from Center Dressing Table (A) and assemble the Handle (6) with handle screw (7) as shown on a diagram.

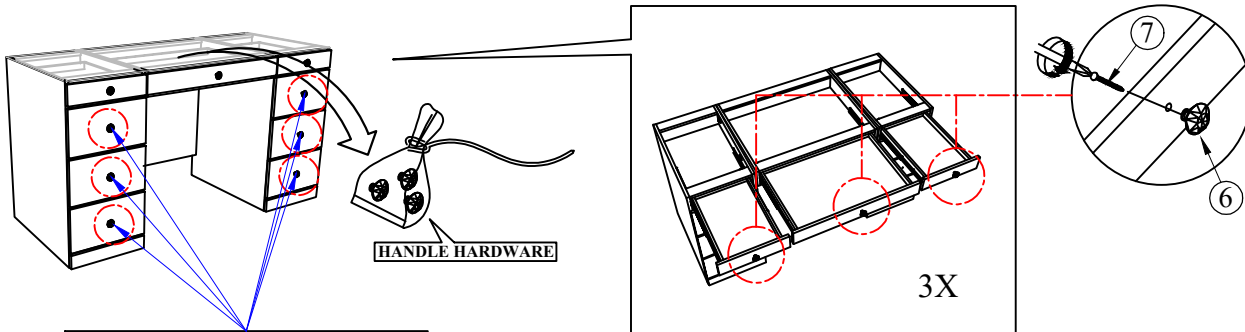

**STEP 4.1**      **6X**      **STEP 4.2**

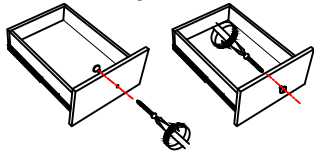

**STEP 5 :** Paste Door Bubble Sticker on top of L & R Side Dressing Table and Center Dressing Table as shown.

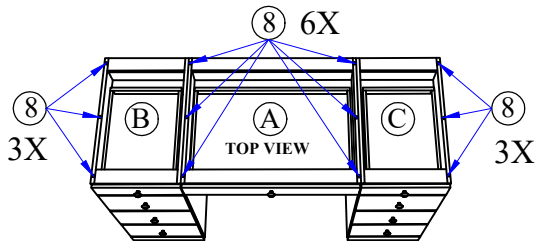

**STEP 6 :** Put the Dressing Top Glass (E) gently on the Door Bubble as shown.

**WARNING! : Need two Peoples to place the top glass.**

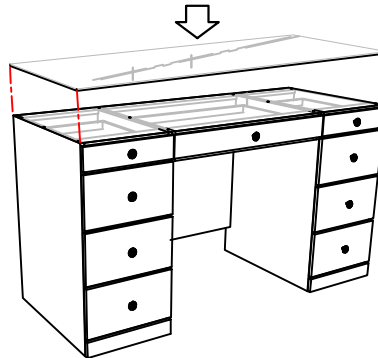

**COMPLETE ASSEMBLY**