

ASSEMBLY INSTRUCTIONS





B6840-Q-HBFB/B6840-KQ-POST

B6845-Q-HBFB/B6845-KQ-POST





QUEEN HEADBOARD/FOOTBOARD/POST

CRWN

(BOX 1) - BOX OF QUEEN HEADBOARD AND FOOTBOARD

PARTS LIST				HARDWARE LIST			
NO.	DESCRIPTION	SKETCH	QTY	NO.	DESCRIPTION	SKETCH	QTY
1	HEADBOARD PANEL		1	A	JCBC (M6 x 35mm) W/FLAT WASHER & SPRING WASHER		12
2	FOOTBOARD PANEL		1	B	ALLEN KEY (M4)		1
				C	WOOD DOWEL (Ø8 x 30mm)		8

(BOX 2) - BOX OF QUEEN/KING POST

PARTS LIST			
NO.	DESCRIPTION	SKETCH	QTY
1	HEADBOARD POST LEFT		1
2	HEADBOARD POST RIGHT		1
3	FOOTBOARD POST LEFT		1
4	FOOTBOARD POST RIGHT		1

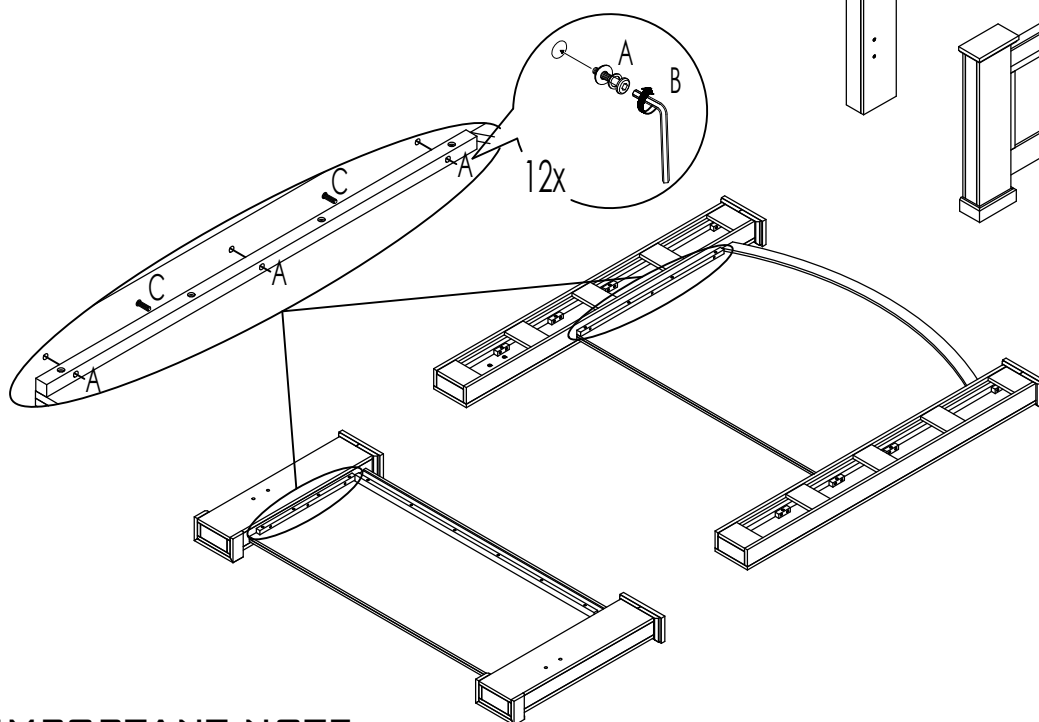
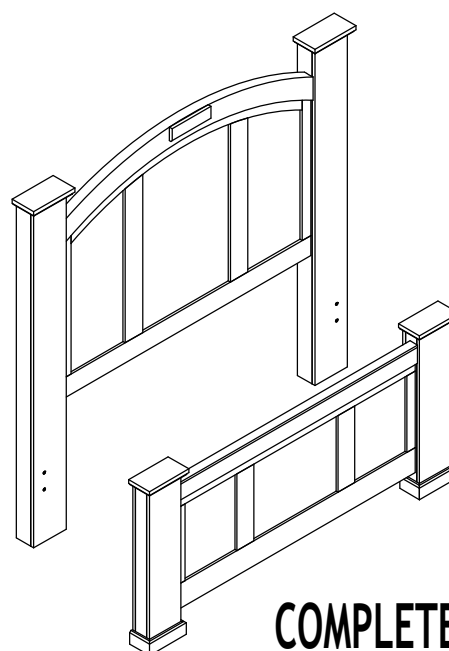

IMPORTANT NOTE :

- * Place all wooden parts on a clean and smooth surface such as a rug or carpet to avoid the parts from being scratched.
- * Check to be sure that you have all parts and hardware.
- * Remove all wrapping materials, including staples & packing straps before you start to assemble.
- * Do not tighten all screws/bolts until all completely assembled.
- * Keep all hardware parts out of reach of children.
- * Periodically check to ensure that all connectors (bolts, screws, etc.) are tight.







THE HARDWARE IS LOCATED IN THE PACKING ITEMS

ASSEMBLY INSTRUCTIONS

B6840-Q-HBFB/B6840-Q-RAIL/B6840-KQ-POST B6845-Q-HBFB/B6845-Q-RAIL/B6845-KQ-POST QUEEN BED



CRWN

(BOX 3) - BOX OF QUEEN SIDE RAIL

PARTS LIST				HARDWARE LIST			
NO.	DESCRIPTION	SKETCH	QTY	NO.	DESCRIPTION	SKETCH	QTY
1	SIDE RAIL		2	A	JCBB (M8 x 20mm) W/FLAT WASHER		8
2	SLAT		4	B	ALLEN KEY (M5)		1
3	VERTICAL LEG		4	C	PANHEAD (M4 x 30mm)		8
				D	SCREW DRIVER (*)		1

*The manufacturer does not provide item D.

(BOX 1 & 2) - BOX OF QUEEN HEADBOARD / FOOTBOARD AND POST **AFTER COMPLETE SET UP

PARTS LIST			
NO.	DESCRIPTION	SKETCH	QTY
4	HEADBOARD		1
5	FOOTBOARD		1

IMPORTANT NOTE :

- * Place all wooden parts on a clean and smooth surface such as a rug or carpet to avoid the parts from being scratched.
- * Check to be sure that you have all parts and hardware.
- * Remove all wrapping materials, including staples & packing straps before you start to assemble.
- * Do not tighten all screws/bolts until all completely assembled.
- * Keep all hardware parts out of reach of children.
- * Periodically check to ensure that all connectors (bolts, screws, etc.) are tight.

