







ASSEMBLY INSTRUCTIONS

ITEM : B9230-2 NIGHTSTAND
B9235-2 NIGHTSTAND

BOX OF NIGHTSTAND PART LIST

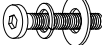
ITEM	DRAWING	DESCRIPTION	QTY
A		NIGHTSTAND	1
B		LEG B	2
C		LEG C	2

BOX OF NIGHTSTAND HARDWARE LIST

ITEM	DRAWING	DESCRIPTION	QTY
1		JCBC SCREW M6 x 40MM	4 PCS
2		WOOD DOWEL Ø8 x 30MM	4 PCS
3		ALLEN KEY M4 x 65MM	1 PC
4		TIPPING RESTRAINT * Located in the nightstand 1st drawer.	1 PC

ASSEMBLY TOOLS REQUIRED

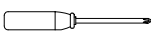
SCREWDRIVER (NOT PROVIDED)		1
-------------------------------	---	---

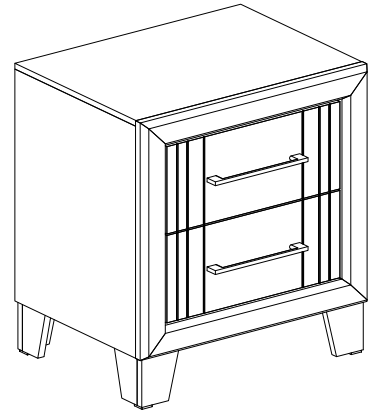

COMPLETED ASSEMBLY

STEP 1

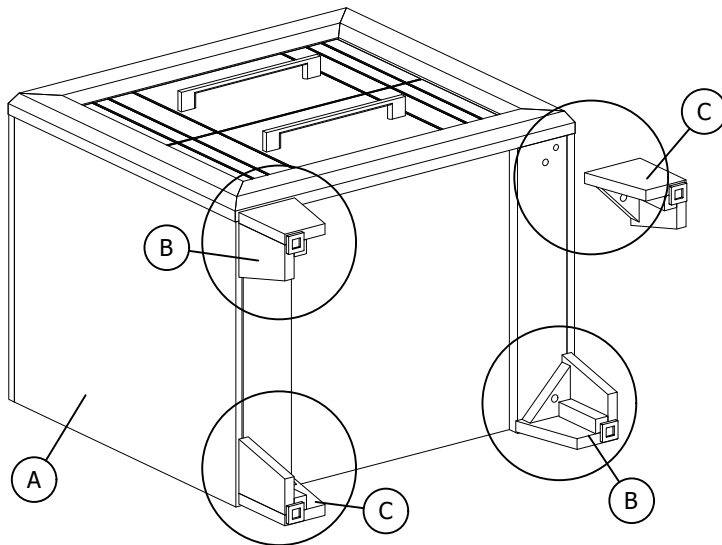

THE HARDWARE IS LOCATED IN THE PACKING ITEMS
THE ANTI TIPPING HARDWARE IS LOCATED IN THE NIGHTSTAND 1ST DRAWER

PAGE 01 OF 02

NOTE : MUST TIGHT SCREWS PERIODICALLY. WITH USE SCREWS MAY BECOME LOOSE.
CHECK TIGHTNESS OF ALL SCREWS EVERY 6-8 WEEKS.

MADE IN MALAYSIA

ASSEMBLY INSTRUCTIONS

ITEM : B9230-2 NIGHTSTAND
B9235-2 NIGHTSTAND

STEP 2

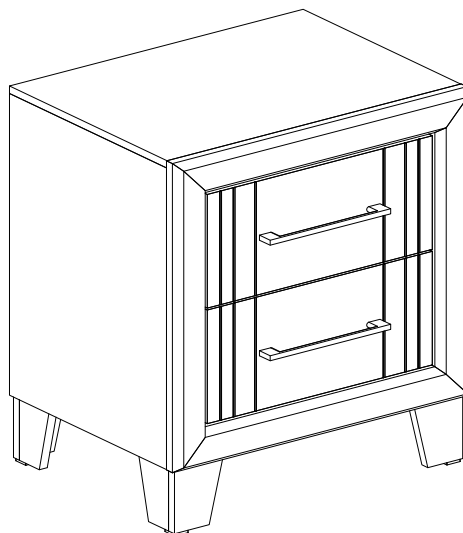
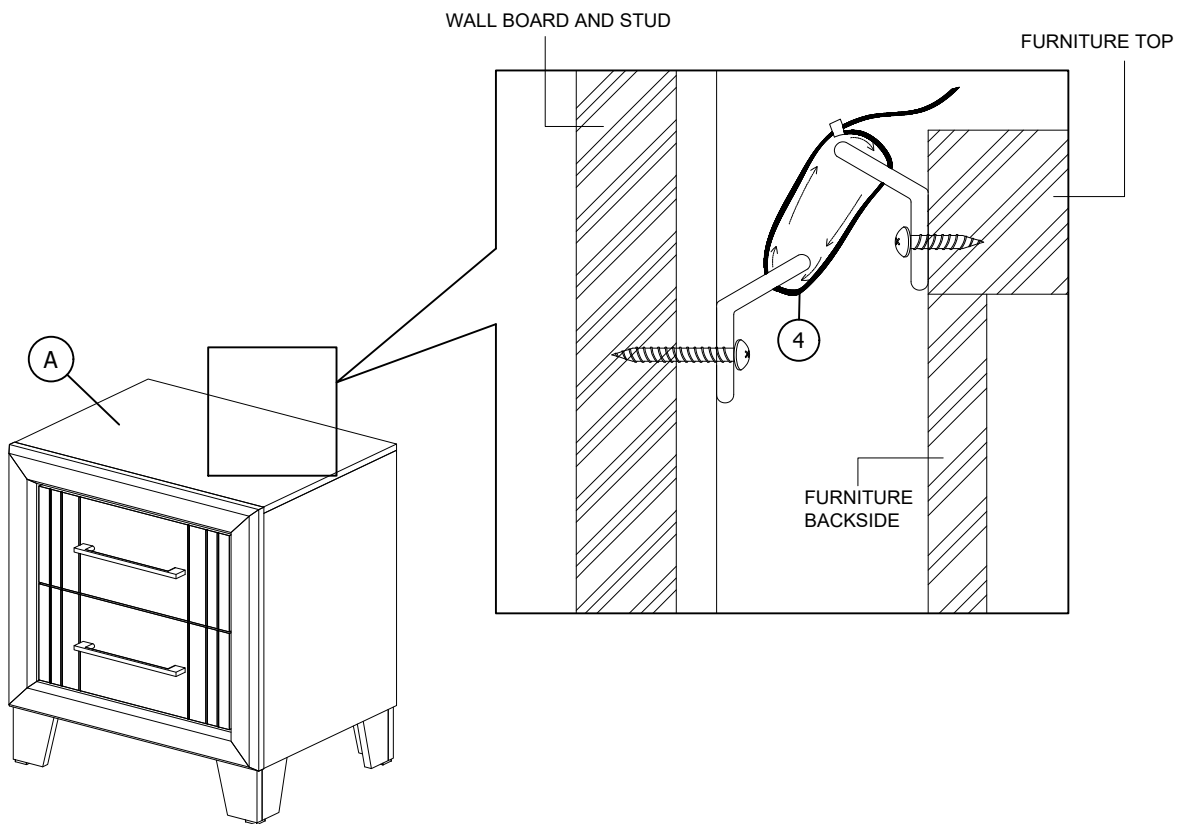

COMPLETED ASSEMBLY

THE HARDWARE IS LOCATED IN THE PACKING ITEMS
THE ANTI TIPPING HARDWARE IS LOCATED IN THE NIGHTSTAND 1ST DRAWER

PAGE 02 OF 02

NOTE : MUST TIGHT SCREWS PERIODICALLY. WITH USE SCREWS MAY BECOME LOOSE.
CHECK TIGHTNESS OF ALL SCREWS EVERY 6-8 WEEKS.

MADE IN MALAYSIA