

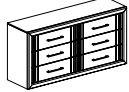







# ASSEMBLY INSTRUCTIONS

ITEM : B9230-1 DRESSER  
B9235-1 DRESSER

## BOX OF DRESSER PART LIST

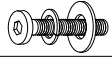
ITEM	DRAWING	DESCRIPTION	QTY
A		DRESSER	1
B		LEG B	2
C		LEG C	2
D		CENTER SUPPORT LEG	1

## BOX OF DRESSER HARDWARE LIST

ITEM	DRAWING	DESCRIPTION	QTY
1		JCBC SCREW M6 x 40MM	4 PCS
2		WOOD DOWEL Ø8 x 30MM	4 PCS
3		ALLEN KEY M4 x 65MM	1 PC
4		TIPPING RESTRAINT * Located in the dresser 1st right side front drawer.	1 PC



COMPLETED ASSEMBLY

## ASSEMBLY TOOLS REQUIRED

SCREWDRIVER (NOT PROVIDED)		1
-------------------------------	---	---

## STEP 1

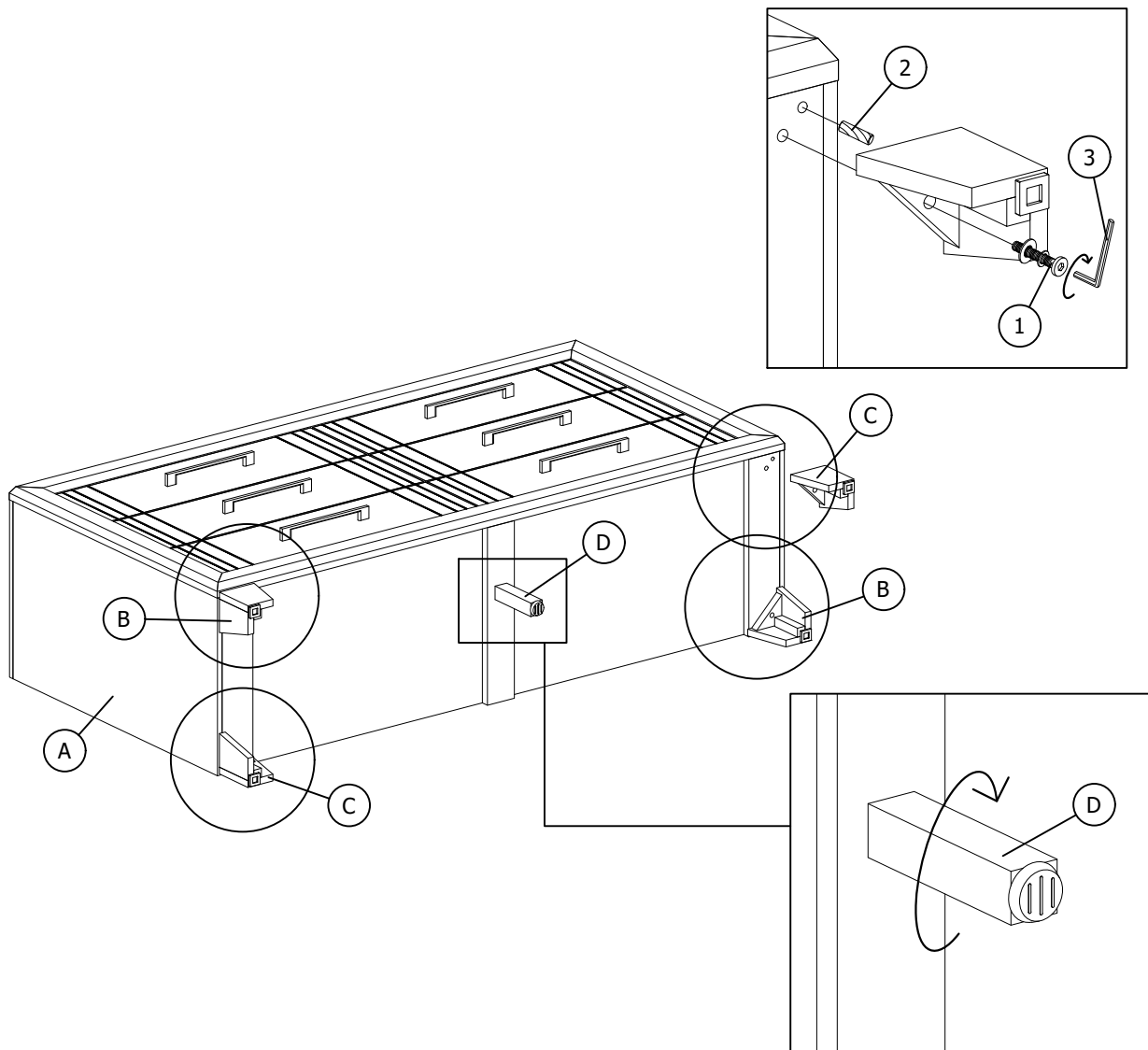

THE HARDWARE IS LOCATED IN THE PACKING ITEMS

THE ANTI TIPPING HARDWARE IS LOCATED IN THE DRESSER 1ST RIGHT SIDE FRONT DRAWER

PAGE 01 OF 02

NOTE : MUST TIGHT SCREWS PERIODICALLY. WITH USE SCREWS MAY BECOME LOOSE.  
CHECK TIGHTNESS OF ALL SCREWS EVERY 6-8 WEEKS.

MADE IN MALAYSIA

# ASSEMBLY INSTRUCTIONS

ITEM : B9230-1 DRESSER  
B9235-1 DRESSER

## STEP 2

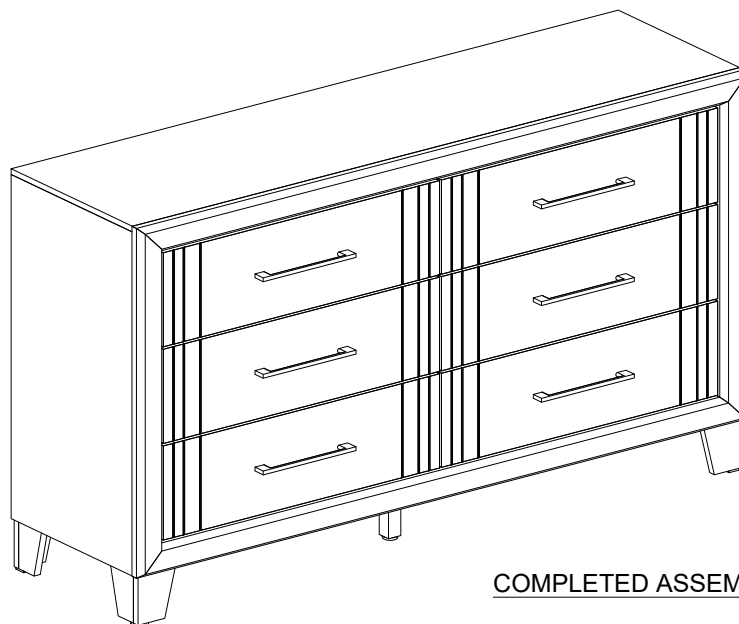
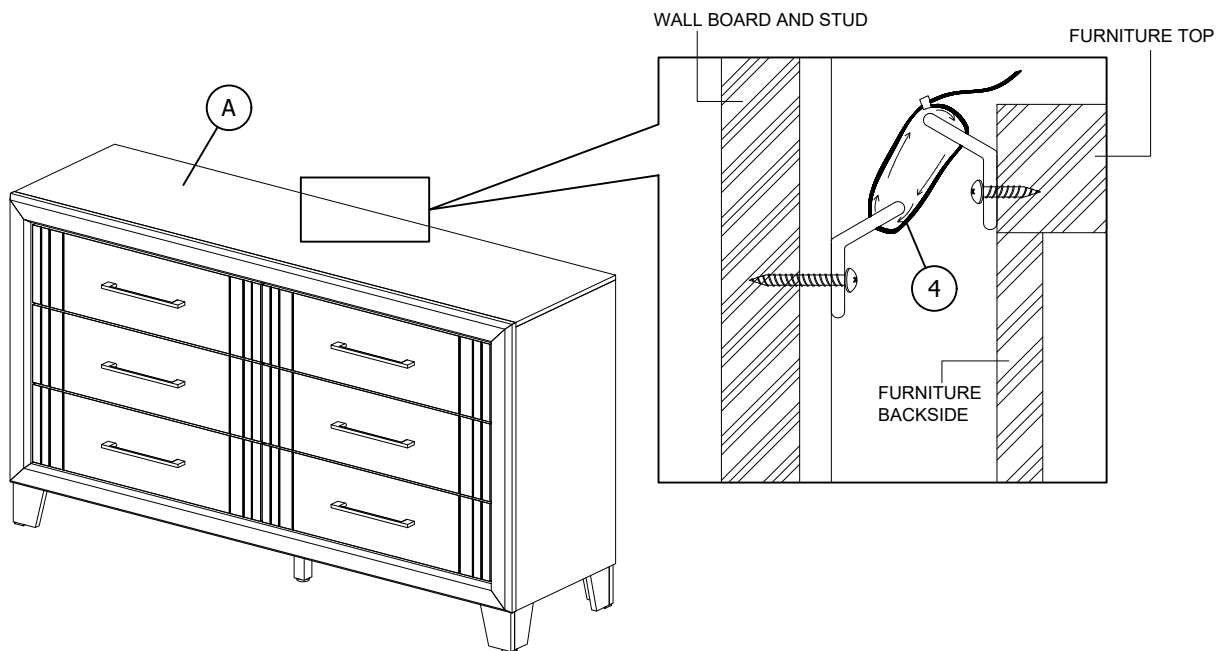

COMPLETED ASSEMBLY

THE HARDWARE IS LOCATED IN THE PACKING ITEMS

THE ANTI TIPPING HARDWARE IS LOCATED IN THE DRESSER 1ST RIGHT SIDE FRONT DRAWER

PAGE 02 OF 02

NOTE : MUST TIGHT SCREWS PERIODICALLY. WITH USE SCREWS MAY BECOME LOOSE.  
CHECK TIGHTNESS OF ALL SCREWS EVERY 6-8 WEEKS.

MADE IN MALAYSIA