

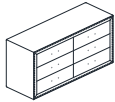





# ASSEMBLY INSTRUCTION

ITEM : B9260-1 / B9265-1 DRESSER

## BOX OF DRESSER DRESSER

ITEM	DRAWING	DESCRIPTION	QTY
A		DRESSER	1
B		LEG	4
C		SUPPORT LEG (Located in the bottom drawer)	1
D		GLASS (Packed in an inner box inside the Dresser) <b>please handle with care</b>	1
E		TIPPING RESTRAINT (Affix dresser to wall) *Located in the top right side front Drawer of the Dresser	1

## BOX OF DRESSER HARDWARE LIST

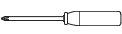
ITEM	DRAWING	DESCRIPTION	QTY
1		JCBC SCREW M6x20mm	8
2		L-KEY M4x65mm	1
		SCREWDRIVER not included	

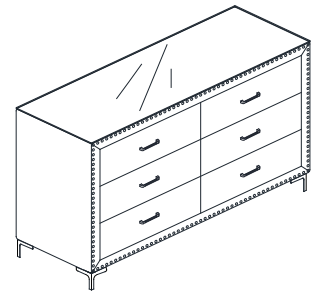

COMPLETED DRESSER ASSEMBLY

**NOTE : GLASS HANDLE WITH CARE "FRAGILE"**

### STEP 1

Note : Set aside the carton D " GLASS"  
before affixing the legs to the Dresser

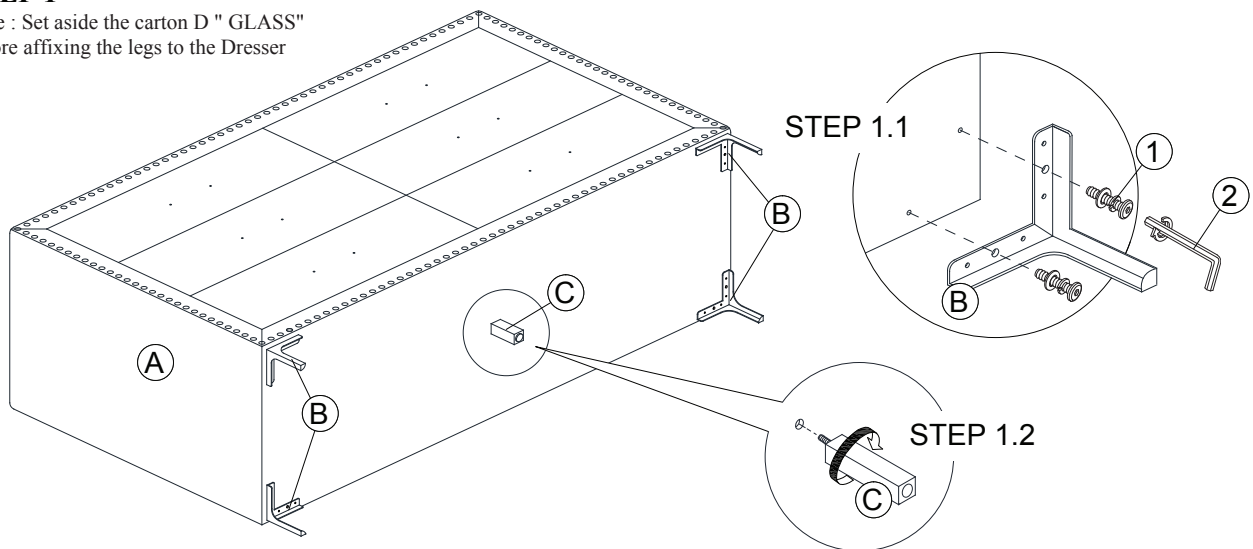

### STEP 2

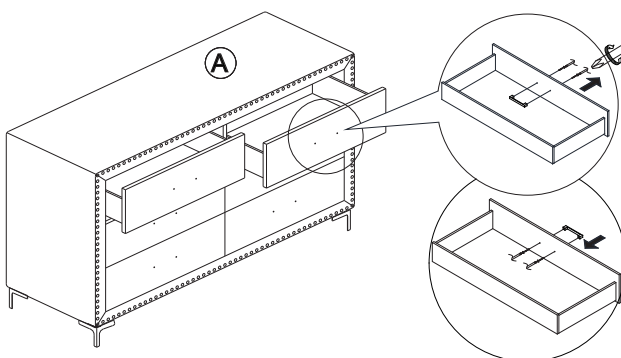

### STEP 3

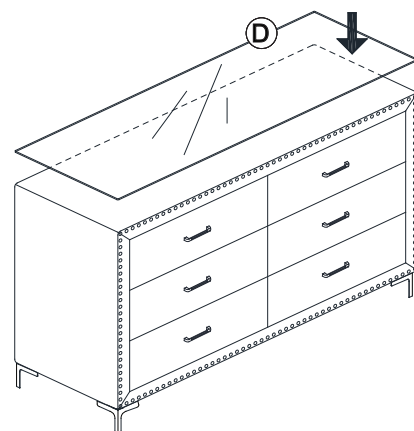

THE HARDWARE IS LOCATED IN THE PACKING ITEMS

THE ANTI TIPPING HARDWARE IS LOCATED IN THE TOP RIGHT SIDE FRONT DRAWER OF THE DRESSER.

**NOTE : MUST TIGHTEN SCREWS PERIODICALLY. WITH USE SCREWS MAY BECOME LOOSE.  
CHECK TIGHTNESS OF ALL SCREWS EVERY 6-8 WEEKS.**

**MADE IN MALAYSIA**