







# ASSEMBLY INSTRUCTION

ITEM : B9290-1 DRESSER

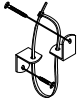
## BOX OF DRESSER DRESSER

ITEM	DRAWING	DESCRIPTION	QTY
A		DRESSER	1
B		METAL LEG	4
C		TIPPING RESTRAINT (Affix to wall behind chest) *Located in the chest 1st drawer	1
D		CENTRE LEG	1

## BOX OF DRESSER HARDWARE LIST

ITEM	DRAWING	DESCRIPTION	QTY
1		JCBC SCREW M6x15mm	12
2		L-KEY M4x65mm	1

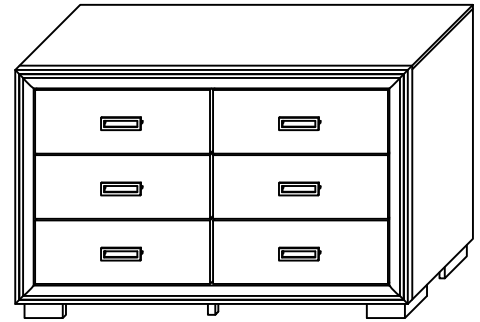

COMPLETED DRESSER ASSEMBLY

## STEP 1

The metal legs are inside the box in one of last drawer.

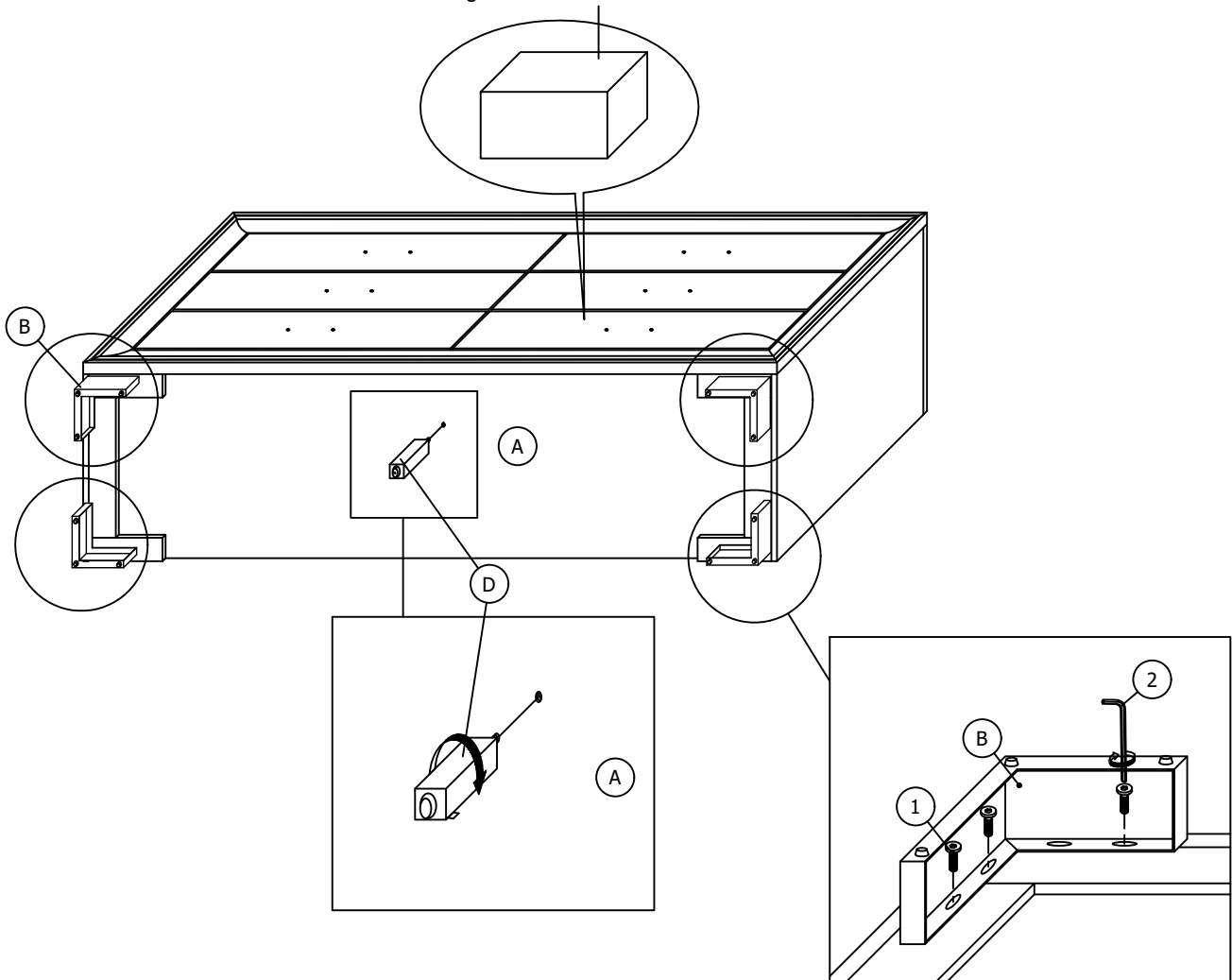

THE HARDWARE IS LOCATED IN THE PACKING ITEMS  
THE ANTI TIPPING HARDWARE IS LOCATED IN THE 1ST RIGHT SIDE FRONT DRAWER OF DRESSER.

PAGE 01 OF 02

NOTE : MUST TIGHT SCREWS PERIODICALL. WITH USE SCREWS MAY BECOME LOOSE.  
CHECK TIGHTNESS OF ALL SCREWS EVERY 6-8 WEEKS.

MADE IN MALAYSIA

# ASSEMBLY INSTRUCTION

ITEM : B9290-1 DRESSER

## STEP 2

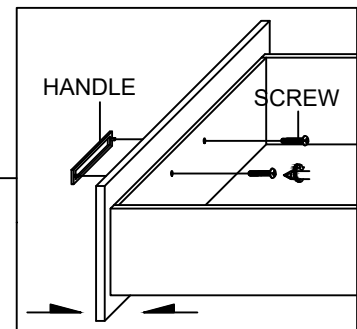
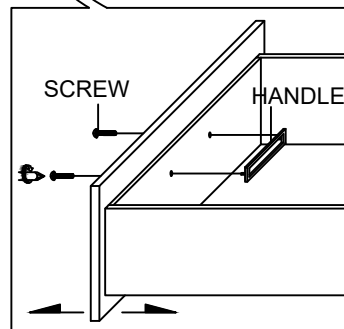
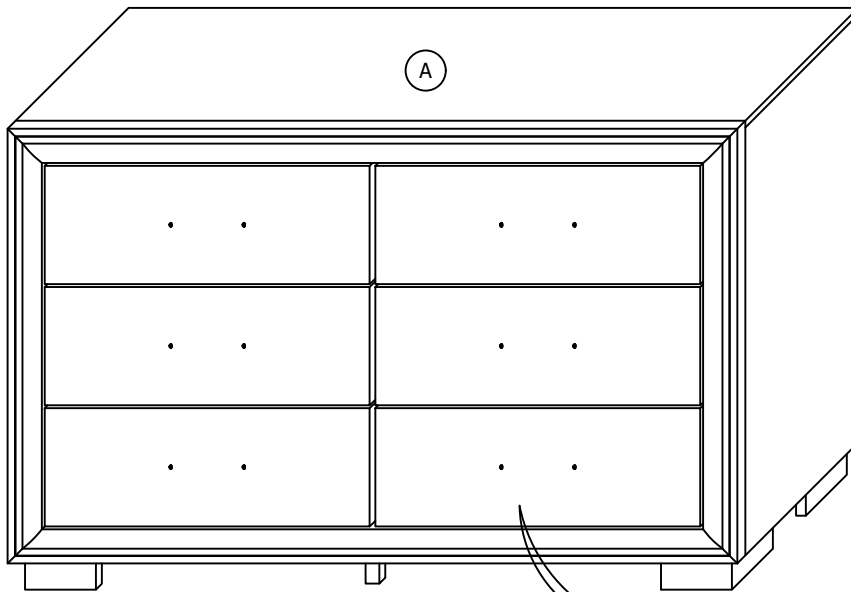

## STEP 3

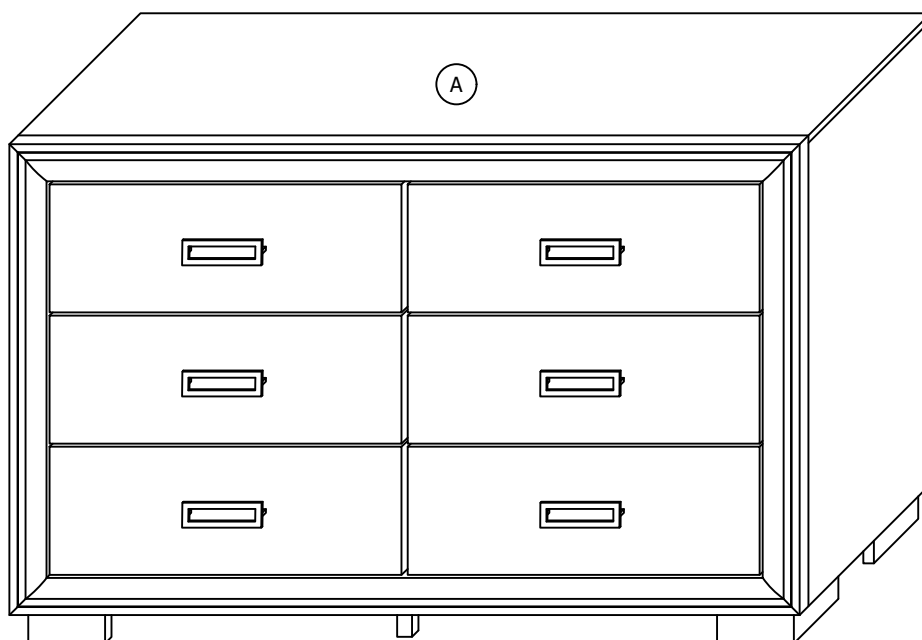

THE HARDWARE IS LOCATED IN THE PACKING ITEMS  
THE ANTI TIPPING HARDWARE IS LOCATED IN THE 1ST RIGHT SIDE FRONT DRAWER OF DRESSER.

PAGE 02 OF 02

NOTE : MUST TIGHT SCREWS PERIODICALL. WITH USE SCREWS MAY BECOME LOOSE.  
CHECK TIGHTNESS OF ALL SCREWS EVERY 6-8 WEEKS.

MADE IN MALAYSIA